

BHARAT SANCHAR NIGAM LIMITED

(A Govt. of India Enterprise)

**O/O GENERAL MANAGER
TELECOM DISTRICT SHIMLA**

BID DOCUMENT

**E-Tender For Optical Fibre Cable
Construction Works**



Connecting India

CHAPTER-I
BHARAT SANCHAR NIGAM LIMITED
(A Govt. of India Enterprise)
OFFICE OF THE, GMTD Shimla, Block No. 35 SDA Complex, Kasumpti-171009
Detailed Notice Inviting Tender

No:-002/515/2016-17/Tender/OFC Patch Work/Plg/ Vol-II/06

Dated: 27.08.2016

Properly Sealed tenders (with packing PVC tape/ Sealing Wax) are invited by the General Manager, Telecom District, Shimla from the reputed contractor(s) for laying of OF cable in PLB pipe underground duct along with associated work in following routes:-

Cost of tender document =Rs 1138/-

Description of work	Total Length of Patches where U/G OFC to be laid(KMs)	Estimated Cost (Rs)	EMD(Rs)
Laying of U/G OFC in Patches in Shimla & Rohru telegraph Divisions	21.600 KMs	7495082.00	187377.00

Note :

1. Intending eligible bidders may visit <http://www.tenderwizard.com/BSNL>.
2. All the documents enumerated in Clause No 3.3 of Chapter-III of Tender Document should be scanned and uploaded on website <https://www.tenderwizard.com/BSNL> within the time period of bid submission.

Eligibility Condition: The prospective bidders should satisfy following conditions

- a) He should have completed work of trenching , laying & splicing of OFC in BSNL/MTNL/PSU/Govt. department as per detail given below during last seven years ending last day of month previous to one in which the tenders are invited:
 - I Three similar completed works each costing not less than the amount equal to 40% of estimated cost of route/routes for which he applies. OR
 - II Two similar completed works each costing not less than the amount equal to 50% of estimated cost of route/ routes for which he applies OR
 - III one similar completed works costing not less than the amount equal to 80% of estimated cost of route/ routes for which he applies .The Experience certificate should be issued by an officer not below than the rank of JAG or Equivalent.

1. Schedule for Inviting the Tender

- 1.1. Designation and address of the authority inviting tender – AGM (Planning) O/o GMTD Shimla -171009
- 1.2. Time and last date of issue of Bid Document ----- 15.00 Hrs of 23.09.2016
- 1.3. Time and Date of online submission of Tender/Bid -----15.00 Hrs of 23.09.2016
- 1.4. Time and Date upto which documents ----- 14:30 Hrs of 24.09.2016
are to be submitted to AGM (Planning) O/o GMTD Shimla consisting of EMD, Bid cost and copy of documents uploaded online.
- 1.5. Time and date of opening of Tender (Technical Bid) ----- 15:00 Hrs. of 24.09.2016.
Minimum Validity of Tender offer ----- 150 days from the date of opening.
- 1.7. Duration of contract -----One Year with an option of extension for one more year
2. Bid Security amount required to be attached with tender form & shall be in the form of crossed demand draft on any Scheduled Bank in favour of AO (Claim) o/o GMTD Shimla 171009 . Tender without Bid Security shall not be entertained.
3. In case the last date of submission/opening of the tender happens to be a holiday, the next working day shall be treated as date of submission/opening of tender, if not mentioned otherwise.
4. The tender will not be opened if it is not wax/ properly sealed.
5. All the rules, terms & conditions are mentioned in the tender form.
6. The GMTD Shimla reserves the right to accept/cancel the tender or any bid without assigning any reason whatsoever.

7. Important Instruction to Bidders Regarding Online Tendering (E-Tendering) :

- (i) Bidder is required to have class 3 digital signature certificate (DSC).
- (ii) Every bidder has to get himself registered on www.tenderwizard.com/BSNL. He has to pay online registration charges depending on his category to M/s ITI Limited (tenderwizard.com) while having registration. The payment will be made online.
- (iii) For Registration: open website www.tenderwizard.com/BSNL >> Register Me >> Read Instruction Carefully >> Fill Form >> Upload Credential Documents >> Make Registration Charges Payment >> Save Acknowledgement >> Send request Letter on your letter pad (scanned copy) alongwith the documents you uploaded while having registration through email to twhelpdesk680@gmail.com to activate your User Id. After sending of request letter and other documents by you, your user id will be activated within one working day and you will be intimated through email. After activation of your user id you will be able to login.
- (iv) To request for tender documents and participate in tender, bidder has to request/apply online through www.tenderwizard.com/BSNL .
- (v) For any help, please contact on 011-49424365 or 0172-3953753. A user manual for vendor (bidder) is also available. (Home page >>Click to view latest circulars / Formats / Manuals >> General >> Vendor Manual_New Version >> Vendor_Detailed_HELP_MANUAL_BSNL.) Bidder has to pay online registration fees to ITI Limited as prescribed at www.tenderwizard.com/BSNL for getting registered for e-tendering. Other than that bidder has to pay processing fees as applicable for each tender depending on the estimated cost of the tender which can be viewed online on www.tenderwizard.com/BSNL.

The bid can only be submitted after uploading mandatory documents like Demand draft or Pay order or banker's cheque or BSNL payment slip for bid document cost and EMD in favour of Accounts Officer (Claim)O/o GMTD BSNL, Shimla , H.P.

**AGM (Planning)
O/O GMTD Shimla
Phone no. 0177-2626344**

**CHAPTER II
TENDER INFORMATION**

2.1 Definitions:

- a) The Chief General Manager means the Chief General Manager HP Telecom Circle .
- b) The General Manager means the General Manager (Telecom District), Shimla.
- c) The Deputy General Manager means the Deputy General Manager Telecom, Shimla.
- d) The AGM(P) means all the Assistant General Manager(Planning) O/o GMTD, Shimla.
- e) Representatives of the AGM (Planning) mean the Officer and staff in the Telecom District Shimla deputed by the AGM (Planning) concerned for supervising the works etc.
- f) The jurisdiction of GMTD, Shimla: The jurisdiction of GMTD, Shimla means area covered as per the following table.

S.No.	Name of SSA	Districts covered
1	Shimla	Shimla, Kinnaur, Part of Kullu & Spiti Districts of HP

- g) Divisional Engineer-in-charge: The Divisional Engineer-in-charge means the Divisional Engineer under GMTD Shimla who is in-charge of work.
- h) Site in-charge: The Site in-charge means the Sub Divisional Engineer under DE , who is in-charge of Site .
- i) Site Engineer: Site Engineer means Junior Telecom Officer of BSNL under SDE/DE of concerned Sub-Divisions/Divisions for supervision of the work including 100% measurement at site under site incharge.
- h) A/T Unit: A/T Unit shall mean Acceptance Testing Unit of the BSNL

2.2 **Type of Tender : Single Bid**

2.3 **Payment of bid Security :- (Refer para 3.5 of chapter 3 i.e. instructions to bidders)**

Bid security Shall be paid in the following ways :

- a) Demand Draft :- DD should be issued from a scheduled bank , drawn in favour of 'Accounts officer (Claim), BSNL O/o GMTD, Shimla; payable at 'Shimla'.

2.4 Bid shall remain valid for 150 days from date of opening of the bid. (refer para 3.7 of this document)

2.4.1 Contract Period: - One year. It can be extended with the approval of GMTD Shimla.

2.5 **Place of submission of tender bids :**

Tender bid should be submitted to AGM(Planning) O/o GMTD Shimla, Block No. 35 SDA Complex, Kasumpti-171009. It shall be opened also at the same address.

2.6 A/T officer:- Officer as decided by T&D Circle.

2.7 **PAYMENT TERMS** (refer clause 4.1.8(i) of the tender document)

- a) Payment upto 80% shall be processed on running/final bills based on certification of completion of work by site incharge. Recovery if any will be deducted.
- b) Balance 20% payment will be released on receipt of less depth relaxation from circle office and successful completion of A/T and based on certification of completion of work in all respect for entire section from site incharge.

Date:

Place:

**Signature of tenderer/authorized signatory
With name.....
& Rubber Seal of the tenderer**

CHAPTER – III
GENERAL PROCEDURE AND CONDITIONS

(a) Instruction to Bidder
INTRODUCTION

3.1

DEFINITIONS

1. **BSNL** : The BSNL means BHARAT SANCHAR NIGAM LIMITED, a Government of India Enterprise, with Head Quarters at New Delhi, which invites the tender on behalf of the all references of :

Chief General Manager
General Manager
Deputy General Manager
Divisional Engineer

(Including other officers in the BSNL, whatever designations assigned to them from time to time, who may be the in-charge of direction, supervision, acceptance testing, and maintenance including their successor(s) in the office appearing in various clauses shall be taken to mean the BSNL).

2. **A/T Officer**: An Officer duly authorized by T&D Circle to conduct A/T.
3. **Contract**: The term contract means, the documents forming the tender offer and acceptance thereof. It shall also include the formal agreement executed between BSNL and the contractor, together with the documents referred to therein including these conditions, the specifications, designs, drawings and instructions issued from time to time, by the Divisional Engineer in-charge and all these documents taken together shall be deemed to form one contract and shall be complementary to one another in the contract.
4. **Contractor**: The contractor shall mean the individual, firm or company, whose tender is accepted, undertaking the works and shall include the legal personal representative of such individual or the persons composing such firm or company, or the successors of such firm or company and
5. **Works**: The expression “Works” means all the tasks defined in chapter 6 of this document (i.e. Scope of work & Specifications of work)
6. **Schedule (of rates)**: Schedule(s) referred to in these conditions shall mean the relevant schedule(s) of rates mentioned in the document in the tender form.
7. **Site**: The site shall mean the land/or other places on, into or through which work is to be executed under the contract or any adjacent land, path or street through which, the work is to be executed under the contract or any adjacent land, path or street which may be allotted or used for the purpose of carrying out the contract.
8. **Normal Time or Stipulated Time**: Normal time or stipulated time means time specified in the work order to complete the work.
9. **Extension of Time**: Extension of Time means the time granted by the GMTD, Shimla to complete the work beyond the normal time or stipulated time.
10. **Date of Commencement of Work**: The contractor should commence work from 7th day of the date of issue of work order.
11. **Due date of completion**: Due date of completion shall be the date by which the work shall be completed at site .
12. **Duration of completion of work**: The duration of completion of work shall be worked out based on execution of work at 1.0 Km per 10 days.
13. **Excepted risk**: Excepted risk are risks due to war (whether declared or not), invasion, act of foreign enemies, hostilities, civil war, rebellion, revolution, insurrection, military or usurped power, any acts of Government damages from

aircraft, acts of God, such as earthquake, lightening and unprecedented floods and other causes over which, the contractor has no control and the same having been accepted as such, by the GMTD, Shimla.

3.2 AMENDMENT OF THE BID DOCUMENTS:

- a At any time, prior to the date of submission of bids, BSNL may, for any reason whether suo motto or in response to a clarification requested by a prospective Bidder, modify the bid documents by amendments.
- b The amendments shall be notified in writing or FAX to all prospective bidders on the address intimated at the time of purchase of bid document from B.S.N.L and these amendments will be binding on them.
- c In order to afford prospective bidders reasonable time to take the amendments into account in preparing their bids, BSNL shall ensure that the deadline for the submission/opening of bids is at least seven days away from date of issue of amendment .

3.3 DOCUMENTS TO BE SUBMITTED WITH THE TENDER OFFER:

The bidder shall furnish, following documents along with his tender offer:-

- i. Questionnaire (Tender Profile) and tender form of the Tender document(s), duly filled in and signed by tenderer or his authorized representative (along with seal). All corrections and overwriting must be initialed with date by the tenderer or his authorized representative.
 - ii. Bid Security for an amount as specified in NIT.
 - iii. The copy of Experience certificate (not below the rank of JAG or Equivalent), in proforma 5(A) or any standard proforma of issuing authority.
 - iv. Copy of Service Tax/ Sales Tax/EPF registration certificate/PAN.
 - v. List of qualified experienced personnel, who are working for the tenderer, who will be deployed for carrying out the work.
 - vi. In case of proprietary firm, proprietor certificate from the proprietor of the firm that he is the sole proprietor of the firm.
 - vii. Authenticated valid copy of partnership deed in cases of partnership firm & form-A issued by Registrar of firms.
 - viii. In case of Limited Company, attested copy of articles of association duly registered with Registrar of Company affairs.
 - ix. Original 'Power of Attorney' in case person other than the tenderer has signed the tender document.
 - x. In case of bidder downloading the tender document from Website then he should enclose DD for tender document fee with the tender offer.
- 3.4 The contractor shall produce registration of his firm with EPF and show evidence of EPF contribution in respect of labours/employees employed by the contractor for the execution of works of BSNL before any payment is made to him for the work.

3.5 Bid security:

1. The bidder shall furnish, as part of his bid, a bid security (EMD) for an amount specified in the tender information.
2. Bid Security shall be paid
 - a) In the form of Crossed Demand Draft, issued by a scheduled bank, drawn in favour of Accounts Officer (Claim) , office of GMTD Shimla as stated in tender information
3. No Interest shall be paid by the BSNL on the bid security for any period, what so ever.
4. The bid security is required to protect the BSNL against the risk of bidders conduct, which would warrant the security's forfeiture.

A bid not secured in accordance with Para above shall be rejected by the BSNL as non-responsive.

- i. The bid security of unsuccessful bidder will be refunded as promptly as possible and within 30 days of finalization of tender.
- ii. The successful bidder's bid security will be compulsorily converted in to Security Deposit.

The bid security shall be forfeited;

- i. If a bidder withdraws his bid during the period of bid validity period specified in the bid document or
- ii. If the bidder makes any modifications in the terms and conditions of the tender before acceptance of the offer, which are not acceptable to the BSNL or
- iii. In case of a successful bidder, if the bidder fails to sign the agreement and deposit material security in the stipulated time.

3.6 Bid prices :

The bidder shall give a total composite price inclusive of all taxes and levies excluding **Service TAX as applicable** which is to be shown separately in bill for works to be executed. The contractor shall be responsible for transporting the material, to be supplied by BSNL (at the designated telecom store) or otherwise to execute the work under the contract, to site at his/their own cost. The costs of transportation are subsumed in the Standard Schedule of Rates and therefore no separate charges shall be payable on this account. The offer shall be firm in Indian Rupees.

- (i) Prices shall be quoted by the bidder for each item in the tender form financial bid in figures & words. Prices quoted at any other place shall not be considered.
- (ii) The price quoted by the bidder shall remain fixed during the entire period of contract and shall not be subject to variation on any account. A bid submitted with an adjustable price quotation will be treated as non-responsive and rejected summarily.
- (iii) Discount, if any, offered by the bidders shall not be considered unless they are specifically indicated in Tender form. Bidders desiring to offer discount shall therefore modify their offers suitably while quoting and shall quote clearly net price taking all such factors like Discount, free supply, etc., into account.

3.7 PERIOD OF VALIDITY OF BIDS :

Bid shall remain valid for days specified in 2.4 of tender information from date of opening of the bid. A BID VALID FOR A SHORTER PERIOD MAY BE REJECTED BY BSNL AS NON-RESPONSIVE.

3.8 SIGNING OF BID:

- a. The bidder shall submit, as a part of his bid, the bid documents duly signed on **Questionnaire & Tender form**, establishing the conformity of his bid to the bid documents of all the works to be executed by the bidder under the contract.
- b. The bid shall contain no inter-lineation, erasures or overwriting except as necessary to correct errors made by the bidder in which case such corrections shall be signed with date by the person or persons signing the bid.

3.9 Method of preparation of bid:

- a. Bid for the tender should be submitted in an envelope . This envelope should contain the document as per para 3.3 & should be submitted in the manner given below :
The envelope must bear the following:

Tender for OF Cable construction Works, NIT no. :

due on

Section

- b. The tenderer will be bound by all terms, conditions & specifications as detailed in the tender documents.
- c. Any tender with conditions other than those specified in the tender document is liable to be summarily rejected. No modification by the contractor in any of the conditions will be permitted after the tender is opened.

3.10 SUBMISSION OF BIDS (Hardcopy) :-

- 3.10.1 The bid should be submitted in one cover. The cover shall contain the original bid duly marked "**Technical Bid**" and it shall contain
- (i) Eligibility Documents as per Eligibility clause of chapter-I and Clause No: 3.3 of Chapter-III of Bid document.
 - (ii) Bid security as per NIT.
 - (iii) Complete bid document dully signed by the authorized representative on each page. The envelope and shall be addressed to the purchaser at the following address:

**AGM(Planning)
o/o GMTD Shimla
SDA Complex Block-35
Kasumpti Shimla-9,**

3.10.2 ONLINE SUBMISSION OF BIDS :-

Tender should be submitted online on the website <http://www.tenderwizard.com/bsnl> and all the uploaded documents except the price bid shall be deposited in a wax/tape sealed envelope to **AGM(Planning) O/o GMTD Shimla SDA Complex Block-35 Kasumpti Shimla-9**, on as per schedule in Chapter-I of NIT .

d **LATE BIDS:**

Tenders will not be received after the specified time of closing of the tender and the same shall be **rejected and returned unopened to the bidder**. It is the sole responsibility of the tenderer that he should ensure timely submission of tender.

3.11 MODIFICATIONS AND WITHDRAWAL OF BIDS:

- a The bidder may modify or withdraw his bid after submission and before closing of tender, provided that the intimation is deposited by the bidder in a properly sealed envelope (with Wax sealed/Packing PVC tape) to AGM(Planning) before the schedule time & date for closing of tender.
- b No bid shall be modified subsequent to the deadline for submission of bids

3.12 BID OPENING AND EVALUATION:

3.12.1 OPENING OF BIDS BY BSNL :

- a. BSNL shall open the bids in the presence of bidders or their authorized representatives who choose to attend, at prescribed time in NIT. on due date. The bidder's representatives who are present, shall sign in attendance register. The bidder shall submit authority letter to this effect before they are allowed to participate in the bid opening (A format is given in **proforma 5(B)** of tender document)
- b Only one representative for any bidder shall be authorized and permitted to attend the bid opening.

3.12.2 The Bids shall be opened in the following manner:

- a. The bid opening committee shall count the number of bids and arrange them in alphabetic order as per name of the firm & assign serial numbers to the bids. For example, if 10 tenders have been received the bids shall be numbered as 1 of 10, 2 of 10 etc. All the TOC members shall put initial on the envelopes as well as tender form of all the bids with date.
- b. The envelopes containing the tender offer and not properly sealed, shall not be opened and shall be rejected outright. Closing the cover by gum, will not be treated as sealed cover. The reasons for not opening such tender offers shall be recorded on the face of the envelope and all the members of bid opening committee shall initial with date.

3.13 CLARIFICATION OF BIDS BY BSNL:

To assist in examination, evaluation and comparison of bids, BSNL may, at its discretion ask the bidder for clarification of its bid. The request for its clarification and its response shall be in writing. However, no post bid clarification at the initiative of the bidder shall be entertained.

3.14 EVALUATION OF BIDS:

- a BSNL shall evaluate each bid to determine whether the same meet the technical and commercial requirement of this tender.
- b If there is discrepancy between words and figures, the amount in words shall prevail. If the tenderer does not accept the correction of the errors, his bid shall be rejected.
- c BSNL will determine the substantial responsiveness of each bid to the bid document. For the purpose of these clauses a substantially responsive bid is one which conforms to all the terms and conditions of the bid documents without deviations. BSNL's determination of bid's responsiveness shall be based on the contents of the bid itself without recourse to extrinsic evidence.
- d A bid determined as substantially non responsive will be rejected by BSNL and shall not, subsequent to the bid opening, be made responsive by the bidder by correction of the non-conformity.
- e BSNL may waive any minor infirmity of non-conformity or irregularity in a bid which does not constitute a material deviation, provided such waiver does not prejudice or affect the relative ranking of the bidder.

3.15 a) The comparison of responsive bids shall be based on rates quoted for all item.

3.16

- a No bidder shall try to influence BSNL on any matter relating to his bid, from the time of bid opening till the time of contract is awarded.
- b Any effort by the bidder to modify his bid or influence BSNL in BSNL's bid evaluation, bid comparison or the contract award decision shall result in the rejection of the bid.

3.17 AWARD OF CONTRACT:

BSNL shall consider award of contract only to those eligible bidders whose offers have been found technically, commercially and financially acceptable.

3.18 BSNL'S RIGHT TO VARY QUANTUM OF WORK:

Estimated cost of work is as mentioned in NIT. The actual value of work may vary based on actual requirement but generally being limited to +/-25% of indicated value.

3.19 BSNL reserves the right to accept or reject any bid and to annul the bidding process and reject all bids, at any time prior to award of contract without assigning any reason what-so-ever and without thereby incurring any liability to the affected bidder or bidders on the grounds for the BSNL's action.

3.20 **LETTER OF ACCEPTANCE:**

- a The letter of Acceptance shall be issued to the accepted bidder with the intention of BSNL to enter into the contract with the bidder.
- b The bidder shall within 10 days of issue of Letter of Acceptance (LOA), give his acceptance along with Security Deposit .

3.21 **Security Deposit:**

Amount of Security Deposit will be 10% of the contract value of Tender. As soon as the tender is approved by the competent authority, the Bid Security (2.5% of Estimated Cost of Tender) deposited by the successful bidder shall be compulsorily converted into the Security deposit, which will be held by the BSNL till the completion of work. Remaining amount of S.D. will be adjusted from the first bill of the contractors.

3.22 **SIGNING OF AGREEMENT:**

The agreement with the successful bidder shall be signed by BSNL within 7 (seven) days of submission of acceptance of LOA. After signing of agreement the contractor will have to deposit material security as per direction from GMTD office.

End of chapter III

CHAPTER - IV

GENERAL TERMS & CONDITIONS OF CONTRACT

4.1 GENERAL (COMMERCIAL) CONDITIONS OF THE CONTRACT

4.1.1 APPLICATION

The General condition shall apply in contracts made by the BSNL for execution of O.F. cable construction works.

4.1.2 STANDARDS

The works to be executed under the contract shall conform to the standards prescribed in the "Scope of work and specification of work" for O.F. Cable construction.

4.1.3 PRICES

- a. Prices quoted by the Contractor for the works performed under the Contract shall not be higher than the prices quoted by him in his contract with private telecom/firms.
- b. Price once fixed will remain valid for the period of contract. Increase and decrease of taxes/duties will not affect the price during this period.

4.1.4 SUBCONTRACTS:

The contractor shall not assign, sub contract or sublet the whole or any part of the works covered by the contract without prior permission from GM TD Shimla.

4.1.5 SECURITY:

i Material Security

- a. The successful tenderer will have to deposit material security of Rs Two Lakh minimum in the form of bank guarantee valid for one and half year from a schedule bank for each section. Material Security can also be submitted in the form of Crossed Demand Draft drawn in favour of AO (Claim) GMTD Shimla O/o GMTD SHIMLA payable at Shimla issued by a scheduled bank. The material Security will be a non interest bearing deposit. Work order will be issued only after receipt of material security.
- b. The value of stores issued to contractor at any point of time will be limited to the amount of material security. If due to any reason the contractor wants more stores to be issued to him then he will be requested to submit additional material security in multiple of One Lakhs of Rupees. In this regard the decision of the GMTD SHIMLA shall be final and binding.
- c. The amount of the material guarantee shall be payable to BSNL as a compensation for any loss resulting from the contractor failure to submit proper account of utilization of material issued to him under the contract.
- d. On receipt of material account and its verification, the Material security shall be released /refunded after payment of the final bill of the work under the contract or final settlement of material account whichever is earlier.

ii Performance Guarantee

The BSNL may issue work order to contractor with stipulation to pay Performance Guarantee which will be deducted from running bills of the contractor, at the time of making any payment to him for work done under the contract. The amount of performance guarantee shall be as prescribed in clause 3.21 of Chapter-III of tender document. The performance shall be recovered from 1st running bill.

- a. The proceeds of the performance security shall be payable to BSNL as compensation for any loss resulting from the contractor's failure to complete its obligations under the contract.

- b. The performance guarantee shall be refunded on expiry of six month of completion of work or receipt of AT acceptance certificate which ever is later, provided there are no recoveries to be made arising out of poor quality of work, incomplete work and/or violation of any terms and conditions of the contract as stipulated in the bid document.
- c. No Interest will be paid to the contractor on the performance guarantee deposit.

4.1.6 Issue of Work Orders & Time limit

Time frame for carrying out the works:

- a. The contractor is expected to carry out laying of 1.0 Km of O.F. Cable in PLB pipe duct in ten days on an average either through open trenching or HDD as specified in tender information.
- b. Before starting of the work the contractor should undertake the survey of the full route for any underground utilities, in proposed route.
- c. The Work order shall be issued by the Divisional Engineer planning after examining the technical and planning details of the works to be executed.
- d. The Divisional Engineer shall specify the time limit to execution of the work in the work order.
- e. BSNL reserves the right to cancel or modify the scope of work stipulated to be carried out against the work order in the event of change of plan necessitated on account of technical reasons or if in the opinion of the work order issuing authority, the contractor is not executing the work at the required pace.
- f. The work order will be issued only after deposit of material security. The work will be awarded subject to availability of road digging permission.

4.1.7 Measurement ,Inspection, Testing & A/T :

i

Measurement:

- (a) The measurement books are to be maintained by the Site incharge /site Engineer not below the rank of Junior Telecom Officer. The entry shall be made in ink. No entry shall be erased. If a mistake is made, it should be corrected by crossing out the incorrect words or figures and inserting the corrections, the corrections thus made shall be initialed & dated by the officer concerned.
- (b) Responsibility of taking and recording measurements: The measurements of various. items of work shall be taken and recorded in the measurements book issued with each work order. The measurements shall be taken and recorded by an officer not below the rank of Junior Telecom Officer.
The Junior Telecom Officer/Sub Divisional Engineer, directly responsible for supervision of work, shall be responsible for accuracy of 100% of measurements. The Sub Divisional Engineer where Junior Telecom Officer is site engineer shall be responsible for conducting test check of 50% of measurements. The Divisional Engineer shall be responsible for conducting test check of 20% of measurements.
- (c) The contractor shall sign all the measurement recorded in the Measurement Book. This will be considered as an acceptance by the contractor of the measurement recorded in the MB. In case contractor fails to attend the measurement or fails to sign or to record the difference within a week, then the measurements taken by site incharge or by the Site Engineer as the case may be shall be final and binding on the contractor and the contractor shall have no right to dispute the same.
- (d) The Divisional Engineer, before passing the bill for section covered by each set of measurement, may carry out test check. The Contractor shall provide the necessary assistance of labour for re-opening of trench for test check by the Divisional Engineer. Separate payment shall not be made to the contractor for excavation of such test checks. However, no of such test pits shall not be less than 5 per Km of work.

- (e) Measurement of work of cable blowing through pipe/duct will be taken equal to the length of the pipe/duct through which the cable has been blown and not the total length of cable blown through pipe/duct.
- (f) All the measurements should be taken from the top of pipe laid.

ii **INSPECTIONS AND QUALITY CONTROL**

It is imperative that the contractors are fully conversant with the HDD /Open trenching & other associated work and shall be fully equipped to carry out the works in accordance with specifications. The contractors are expected and bound to ensure quality works in accordance with specifications laid down. The contractor shall engage adequate and experienced supervisors to ensure that works are carried out as per specifications and with due diligence and in a professional manner. The Site In-charge will satisfy himself that the work conforms to the specification. before offering the same to A/T wing for Acceptance Testing.

iii **Testing and acceptance testing**

a The work shall be deemed to have been completed only after the same has been accepted by the A/T Officer as per specification given in tender document. The contractor shall make test pits at the locations desired by A/T Officer for conducting test checks without any extra payment. The contractor shall restore the pits after test measurements to its original shape. The contractor shall be responsible to provide test/ measurement tools and testers for conducting various tests.

b **Scope of Acceptance and Testing:** The purpose of acceptance and testing is to verify integrity of measurements and quality of work done. The A/T Officer shall not be responsible for recording of measurements for the purpose of billing and contractual obligations. However, if the measurements taken by A/T Officer are found to be lesser than the measurements recorded by the officer responsible for recording the measurements, the measurements taken by A.T. Officer shall prevail without prejudice to any punitive action against the contractor as per provisions of the contract and the officer recording the measurements. The contractor shall be obligated to remove defects/deficiencies pointed out by the A/T Officer without any additional cost to the BSNL..

c The contractor shall provide labour, if demanded by the Site incharge/Site Engineer for digging of test pits and other necessary infrastructure for carrying out the A/T work. No extra payment will be made for the digging of test pits.

iv **AUDIT AND TECHNICAL EXAMINATION:**

a. BSNL shall have the right to cause an audit and technical examination of the work and the final bills of the contractor including all supporting vouchers, abstract etc. after payment of the final bill and if as a result of such audit and technical examination any sum is found to have been overpaid in respect of any work done by the contractor under the contract or any work claimed by him to have been done by him under the contract and found not to have been executed, the contractor shall be liable to refund the amount of overpayment and it shall be lawful for BSNL to recover the same from him in the manner prescribed in clause under the heading payment of bills , or in any other manner legally permissible and if it is found that the contractor was paid less than what was due to him under the contract in respect of any work executed by him under it, the amount of such under payment shall be duly paid by BSNL to the contractor.

- b. Any sum of money due and payable to the contractor (including security deposit refundable to him) under this contract may be appropriated by BSNL for the payment of a sum of money arising out or under any other contract made by the contractor with BSNL.

4.1.8 PAYMENT TERMS

I. Procedure for Preparation and settlement of bills :

- a) Payment upto 80% shall be processed on running/final bills based on certification of Completion of work in the allotted section by site incharge. Recovery if any will be deducted.
- b) Balance 20% payment will be made on approval of less depth relaxation from circle office on certification of completion of work in all respect for entire section to the satisfaction of site incharge and report of successful completion of A/T from T&D circle.

II. Procedure for Preparation, Processing and Payment of running bills: The Contractor shall prepare the running bills in triplicate ensuring execution of part work in its completeness as envisaged above, correctness of rates and quantum of work and submit the bills to D.E. in-charge of work. The bills shall be prepared accurately and as per measurements recorded in the measurement book and after acceptance and testing of all the items involved in the work. The S.D.E. in-charge of work shall scrutinize the bills and accord necessary certificates and submit the running bills with the documents as mentioned below to the Divisional Engineer, in-charge of work..

- First copy of bill with copy of measurement sheets of measurement book and A/T reports. **(Payable Copy)**
- Second copy of bill. **(Not for Payment)**
- Third copy of the bill with copies of measurement sheets of measurement book and AT Reports (office copy).

III. Procedure for preparation, processing and payment of final bill: The contractor shall prepare the final bill in triplicate after completion of the entire work entrusted against the work order & acceptance and testing of all the works and submit the same to S.D.E in- charge of work and payments shall be made after scrutiny of bill. The final bill shall be prepared for all the measurements of all items involved in execution of complete work order. The contractor shall prepare the final bill containing the following details:

- The bill for all the quantities as per Measurements at the approved rates
- Adjustment of amount received against running bills
- Adjustment of Performance security deposit and statutory taxes already recovered
- Store reconciliation statement furnishing account of stores received against the Work Order and returned to the designated Store as surplus with requisite verification from store in-charge/S.D.E in-charge of work.
- Documentation of the section in soft copy (CD) as well as hard copy.
- Details of empty cable drums cost of which needs to be recovered from the bill if not deposited by the contractor to the store in-charge.
- Copy of service tax paid challan

- **Final bill should be submitted within six months of completion of work. No payment & claim will be admissible if any after due date and case will be treated as time barred and forfeited.**

IV. Checklist Points (To be endorsed on the bill in addition to requisite certificates) :

- Contract No.....dated.... Bill No. dated
- (i) Work has been done satisfactory as per Specifications of contract bearing Number..... date.....
And further w/o Number.....date for the period
 - (ii) Provision exists in Estimate no.....
 - (iii) Rate approved/accepted as per ANXof agreement
 - (iv) All documents have been attached as required as per contract.
 - (v) No complaints received from labours & contractor has complied all statutory obligations required as per labour law.
 - (vi) Nothing is due from contractor.
 - (vii) No damages done by the contractor during performance of duty.
 - (viii) No substandard work has been done & there is no deviation.
 - (ix) No penalty is liable as per clause 4.1.9 .

V. PROCEDURE FOR PAYMENT FOR SUB STANDARD WORKS

1. The contractors are required to execute all works satisfactorily and in accordance with the specifications. If certain items of works are executed with unskilled workmanship or with materials of any inferior quality which is not in accordance with the contract (referred to as sub-standard work, hereinafter), the Divisional Engineer In-charge shall make a demand in writing specifying the work, materials or articles about which there is a complaint.
2. **Timely action by Site incharge/Site engineer** : Timely reporting and action, to a great extent, can prevent occurrence of sub standard work, which will be difficult or impossible to rectify later on. It is incumbent on the part of Site officers to point out the defects in work in time during progress of work. The Junior Telecom Officer/Sub Divisional Engineer responsible for execution and supervision of work shall without any loss

of time submit a report of occurrence of any substandard work to the Divisional Engineer in-charge. A notice in respect of defective work shall be given to the contractor by Divisional Engineer in-charge in writing during the progress of work asking the contractor to rectify/replace/remove the substandard item of work and also definite time period within which such rectification/removal/replacement has to be done. After expiry of notice period, if the contractor fails to rectify/replace/remove the substandard items, the defect shall be got rectified/replaced/removed by BSNL or through some other agency at the risk and cost of the contractor.
3. Non reporting of substandard work in time on the part of the Site Engineer shall not in any way entitle the contractor to claim that the defects were not pointed out during execution and as such the contractor cannot be absolved of the responsibility for substandard work or associated liabilities.

4. **Authority and Procedure to accept substandard work and payment thereof:**
- There may be certain items of work pointed out as substandard which may be difficult to rectify and in the opinion of the GMTD SHIMLA , the items in question will not materially deteriorate the quality of service provided by the construction, the GMTD SHIMLA shall appoint committee to work out the reduced rates payable to the contractor for such substandard work. The committee shall constitute one Divisional Engineer other than the one who is directly in-charge of laying of OF Cable involving substandard items of work, as ;Chairman and one S.D.E (Planning) and an Accounts Officer, as members. The committee shall take into account, the approximate cost of materials/work pointed out as substandard and recommend the rates payable to such substandard work which shall not exceed 60% of the approved rates of the items in question.
5. **Record of substandard work:** The items adjudged as substandard; shall be entered into the measurement with red-ink.

4.1.9

PENALTY CLAUSE :

- i **DELAYS IN THE CONTRACTORS PERFORMANCE**
 1. The time allowed for completion of the work as entered in the tender shall be strictly adhered by the contractor and shall be deemed to be the most important aspect of the contract on the part of the contractor and shall be reckoned from 7th day from the date of issue of work order by BSNL. Penalty of 1.5%(of the bill amount) per week will be imposed for delays caused in the work subject to the maximum of 10% amount of total bill.
 2. On any date the penalty payable as above, reaches 10 (ten) percent of the estimated cost of the work, the contractor should proceed with the work further only on getting a written instructions from the Divisional Engineer planning that, he is allowed to proceed further with the work. It will be at the discretion of the Divisional Engineer to allow the contractor to continue with the work on the basis of any written agreement reached between the contractor and the Divisional Engineer. One of the conditions of such agreement may be a stipulation for the contractor to agree for realization of penalty for delay at a higher rate as may be agreed between the Divisional Engineer and the contractor.
 3. Penalty for delay in completion of the work shall be recoverable from the bills of the contractor and /or by adjustment from the security deposit or from the bills of any other contract. However, adjustment from security deposit will be made only when the contract has been terminated or at the time of final settlement of bills on completion of work.
 4. In case of slow progress of the work in a section which have been awarded to a particular contractor, and the public interest does not permit extension of time limit for completion of the work, the GMTD SHIMLA will have the full right to order that the scope of the contractor may be restricted to such fraction of the whole of the work and get the balance executed at the risk and cost of the contractor. The details are given in Rescission of the contract clause of the bid document. All such payments shall be recovered from the contractor's pending bills or security deposit.

5. The GMTD SHIMLA reserves the right to cancel the contract and to forfeit the security deposit if the contractor fails to commence the work within 7 days of the date of receipt of the work order.

ii Penalty for causing inconvenience to the public:

1. The contractor shall not be allowed to dump the empty cable drums/waste materials in Govt/public place, which may cause inconvenience to Public. If the contractor does not deposit/remove the empty cable drum of such material within 3 days of becoming empty, the BSNL is at liberty to transport all such materials to the store and amount incurred towards transportation will be deducted from his bill/security deposit.
2. If such happening will be done more than two times then the contract will be terminated. In this regard the decision of GMTD SHIMLA shall be final & binding.

iii Penalty for cutting/damaging the existing cable of BSNL

While executing the works the contractor shall take utmost care so that the existing underground cables are not damaged or cut. In case any damage/ cut is done to the existing cables of BSNL, a penalty as per the estimate/bill given by the concerned SSA/Telecom authority as per instructions issued vide BSNL C.O. letter no. 110-7/2002-Regln. Dated 05.10.2004 detailed as under:

S.No.	Size of Cable to be replaced in pairs	Damage charges as prescribed in circular dated 6.10.2003.(Fixed cost in Rs.)	Cost of additional copper cable for each slab of 10 meter (Variable Cost in Rupees per slab of cable of length 10 meter)
		(a)	(b)
1.	5	7,500	4,500
2.	10	7,500	5,000
3.	20	7,500	5,000
4.	50	10,000	5,500
5.	100	10,000	6,000
6.	200	20,000	7,000
7.	400	20,000	11,000
8.	800	40,000	13,000
9.	1200	75,000	17,000

The penalty for damage of existing BSNL OF cable of any size will be charged @ Rs. 1,50,000/- per cut.

iv Penalty for damaging any other utilities.

1. If there is a damage caused to any property of a third party or injury/loss occurs to any person because of lack of proper precaution on the part of the Contractor, the contractor will be held responsible and has to compensate for such damage/injuries/losses to these utilities.
2. If BSNL has to incur any expenditure to repair such damages or to compensate for such injuries/lapses, the amount plus five percent as processing charge will be recovered from the dues of the Contractor or from the security deposit or both.

3. In every case by virtue of the provisions and Workman's Compensation Act the BSNL is obliged to pay compensation to a work man employed by the contractor in charge of the execution of the work, the BSNL will be entitled to recover from contractor the amount of compensation so paid plus five percent processing charge.
4. Insurance coverage for the materials supplied to the contractor must be borne by the contractor for covering the loss if any due to fire, hazardous lifting, explosions, impact by rail / road, vehicle, animal, riot, strike malicious and terrorist damages.
5. The contractor has to appraise himself of the laws/rules/regulations of the concerned local authority and abide by such laws/rules/regulations concerning his work. Any lapses on this account may lead to penalty and prosecution for which the contractor will be solely responsible.

v Penalty to damage stores/materials supplied by the BSNL while laying

1. The contractor while taking delivery of materials supplied by the BSNL at the designated place shall thoroughly inspect all items before taking them over. In case of execution of the work, if any material is found damaged, then a penalty equivalent to the cost of material +10 % as penalty shall be recovered from the contractor's payments/securities.
2. However, contractor will not be penalized for any defect in workmanship of the material, which shall be taken up separately with the supplier of the stores.

4.1.10 RESCISSION OF CONTRACT

i Circumstances for rescission of contract

Under the following conditions the GMTD SHIMLA may rescind the contract:

1. If the contractor commits breach of any item of terms and conditions of contract.
2. If the contractor suspends or abandons the execution of work and the Divisional Engineer in – charge of the work comes to conclusion that work could not be completed by due date for completion or contractor had already failed to complete the work by that time.
3. If the Divisional Engineer in-charge of work had issued a notice to the contractor in writing to rectify/replace any defective work and he/she fails to comply with the requirement within the specified period.

ii Upon rescission of the contract, the security deposit of the contractor shall be forfeited and the same shall lie absolutely at the disposal of the BSNL as under:

1. Measurement of the Works executed since the date of last measurement and up to the date of rescission of contract shall be taken in presence of contractor or his authorized representative who shall sign the same in MB. If the contractor or his authorized representative do not turn up for joint measurement, the measurement shall be taken by the site incharge/ Engineer authorized for this purpose after expiry of due date given for joint measurement. The measurement taken by the officer so authorized shall be final and no further request for joint measurement shall be entertained.
2. The unused material (Supplied by the BSNL) available at site shall be transported back by the BSNL to the telecom store at the risk of contractor. If any

such material is found damaged/lost then the penalty also be recovered from the contractor as per condition in tender documents.

4.1.11 **Issuance of Notice:**

1. The Divisional Engineer in-charge of work shall issue **show cause notice** giving details of lapses, violation of terms and conditions of the contract, wrongful delays or suspension of work or slow progress to the contractor directing the contractor to take corrective action. A definite time schedule for corrective action shall be mentioned in the show cause notice. If the contractor fails to take corrective action within the stipulated time frame, the Divisional Engineer In-charge shall submit a case for issue of final notice along with a detailed report to the competent authority who had accepted the contract.
2. The final notice for rescission of contract to the contractor shall expressly state the precise date and time from which the rescission would become effective. The following safe guards shall be taken while issuing the final notice.
 - a) During the period of service of notice and its effectiveness, the contractor should not be allowed to remove from the site any material/equipment belonging to the BSNL.
 - b) The contractor shall give in writing the tools and plants he would like to take away/remove from the site.
 - c) GMTD Shimla shall neither award any work nor allow him commencement of work to this contractor which are earlier awarded.
 - d) Divisional Engineer in-charge of work shall make adequate BSNL security arrangement in replacement of the contractor watch and ward. Expenses on this account shall be recovered from the security deposit or any amount due to the contractor.

4.1.12 **INDEMNITIES :**

1. The contractor shall at all times hold the BSNL harmless and indemnify from against all action, suits, proceedings, works, cost, damages, charges claims and demands of every nature and descriptions, brought or procured against the BSNL , its officers and employees and forthwith upon demand and without protect or demur to pay to the BSNL any and all losses and damages and cost (inclusive between attorney and client) and all costs incurred in endorsing this or any other indemnity or security which the BSNL may now or at any time have relative to the work or the contractors obligation or in protecting or endorsing its right in any suit on other legal proceeding , charges and expense and liabilities resulting from or incidental or in connection, with injury, damages of the contractor or damage to property resulting from or arising out of or in any way connected with or incidental to the operations caused by the contract document. In addition the contractor shall reimburse the BSNL or pay to the BSNL forthwith on demand without protect or demur all cost, charges and expenses and losses and damages otherwise incurred by it in consequences of any claim, damages

and actions which may be brought against the BSNL arising out of or incidental to or in connection with the operation covered by the contractor.

- 2 The contractor shall at his own cost at the BSNL request defend any suit or other proceeding asserting a claim covered by this indemnity, but shall not settle, compound or compromise any suit or other finding without first consulting the BSNL.

4.1.13

ARBITRATION:

1. In the event of any question, dispute or difference arising under this agreement or in connection there-with except as to matter the decision of which is specifically provided under this agreement, the same shall be referred to sole arbitration of the Chief General Manager, (**Himachal Pradesh**) or in case his designation is changed or his office is abolished then in such case to the sole arbitration of the officer for the time being entrusted whether in addition to the functions of the Chief General Manager, (**Himachal Pradesh**) or by whatever designation such officers may be called (hereinafter referred to as the said officer) and if the Chief General Manager, (**Himachal Pradesh**) or the said officer is unable to act as such to the sole arbitration or some other person appointed by the Chief General Manager, or the said officer. The agreement to appoint an arbitrator will be in accordance with the Arbitration and Conciliation Act 1996. There will be no objection to any such appointment that the arbitrator is BSNL Servant or that he has to deal with matter to which the agreement relates or that in the course of his duties as BSNL Servant has expressed view on all or any of the matter under dispute. The award of the arbitrator shall be final and binding on the parties. In the event of such arbitrator to whom the matter is originally referred, being unable to act for any reasons whatsoever such Chief General Manager or the said officer shall appoint another person to act as arbitrator in accordance with terms of the agreement and the person so appointed shall be entitled to proceed from the stage at which it was left out by his predecessors.
2. The arbitrator may from time to time with the consent of parties enlarge the time for making and publishing the award, subject to aforesaid Indian Arbitration and Conciliation Act 1996 and the rules made there under, any modification thereof for the time being in force shall be deemed to apply to the arbitration proceeding under this clause.
3. The venue of the arbitration proceeding shall be the office of the Chief General Manager, Himachal Pradesh or such places as the arbitrator may decide. The dispute may be requested for arbitration within six months from the date of completion of work by the contractor. The following procedure shall be followed :
 - (i) In case parties are unable to reach a settlement by themselves, the dispute should be submitted or arbitration in accordance with contract agreement.
 - (ii) There should not be a joint submission with the contractor to the sole arbitrator.
 - (iii) Each party should submit its own claim severally and may oppose the claim put forward by the other party.
 - (iv) The onus of establishing his claims will be left to the contractor.
 - (v) Once a claim has been included in the submission by the contractor, a reiteration or modification thereof will be opposed.
 - (vi) The "points of defense" will be based on actual conditions of the contract.
 - (vii) Claims in the nature of ex-gratia payment shall not be entertained by the Arbitrator as these are not contractual.
 - (viii) The question whether these conditions are equitable shall not receive any consideration in the preparation of "points of defense".

- (ix) If the contractor includes such claims in his submission, the fact that they are not contractual will be prominently placed before the Arbitrator. The award of the sole Arbitrator shall be final and binding on all the parties to the dispute.

4.1.14 Set Off

Any sum of money due and payable to the contractor (including security due to him) under this contract may be appropriated by BSNL or any other person or persons contracting through and set off the same against any claim of the BSNL, or such other person or persons for payment of a sum of money arising out of this contract made by the contractor with BSNL such other person or persons contracting through BSNL.

4.2 SPECIAL CONDITIONS OF CONTRACT

4.2.1 GENERAL:

- a. The work shall be accepted only after Officer Incharge of Acceptance Testing accepts the work, as per prescribed schedule and work material passing the test successfully.
- b. BSNL reserves the right to disqualify such bidders who have a record of not meeting contractual obligations against earlier contract agreements entered into with the BSNL.
- c. BSNL reserves the right to blacklist a bidder for a suitable period in case he fails to honour his bid without sufficient grounds.
- d. BSNL reserves the right to counter-offer price(s) against price(s) quoted by any bidder.
- e. Any clarification issued by BSNL, in response to query raised by prospective bidders shall form an integral part of bid documents and it may amount to amendment of relevant clauses of the bid documents.
- f. Tender will be evaluated as a single package of all the terms given in the price schedule.
- g. All works to be executed under the contract, shall be executed under the direction and subject to the approval in all respects of by the Divisional Engineer in – charge of work/site in charge who shall be entitled to direct at what point or points and what manner they are to be commenced, and from time to time carried on.
- h. If the contractor shall desire an extension of time for completion of the work on the grounds of unavoidable hindrance in execution of work or on any other ground he shall apply in writing to the Divisional Engineer concerned within 3 days of the date hindrance on account of which he desires such extension as aforesaid. In this regard the decision of GMTD SHIMLA shall be final.
- i. If at any time after the commencement of the work, BSNL feels that execution of whole or part of work, as specified in the tender is not required to be carried out, then the BSNL shall intimate to the contractor in writing of the fact who shall have no claim to payment of compensation whatsoever on account of any profit or advantage which he might have derived in consequence of the full amount of the work not having been carried out He shall not have any claim for compensation by reason of alterations having been made in the original

specifications, drawings, designs and instructions which shall involve any curtailment of the work as originally contemplated.

- j.** Whenever any claims against the contractor for the payment of a sum of money arises out of or under the contract, BSNL shall be entitled to recover such sum by appropriating in part or whole of the security deposit of the contractor and to sell any Government promissory notes etc., forming the whole or part of such security or running /final bill pending against any contract with BSNL. In the event of the security being insufficient or if no security has been taken from the contractor, then the balance or the total sum recoverable as the case may be, shall be deducted from any sum then due or which at any time there after may become due to the contractor under this or any other contract with Government. Should this sum be not sufficient to cover the full amount recoverable the contractor shall pay to BSNL on demand the balance remaining amount.
- k.** No employee/Officer of BSNL or any PSU or any other Department of Government of India is allowed to work as a contractor during service and for a period of two years after his retirement from Government service without the previous permission of Government of India. This contract is liable to be cancelled if either the contractor or any of his employee is found at any time to be such a person who had not obtained the permission of Government of India as aforesaid before submission of the engagement in the contractor's service as the case may be. In the event of the contractor being, adjudged insolvent or going voluntarily into liquidation or having received order or other order under insolvency act made against him or in the case of company, of the passing of any resolution or making of any order for winding up whether voluntarily or otherwise, or in the event of the contractor failing to comply with any of the conditions herein specified, the GMTD SHIMLA shall have the power to terminate the contract without any notice.
- l.** Without prejudice to any of the rights or remedies under this contract, if the contractor dies, the GMTD SHIMLA can terminate the contact without compensation to the contractor. However the GMTD SHIMLA at his discretion may permit contractor's heirs to perform the duties or engagements of the contractor under the contract, in case of his death. In this regard the decision of GMTD shall be final.
- m.** In the event of the contractor, winding up his company on account of transfer or merger of his company with any other, the contractor shall make it one of the terms and stipulations of the contract for transfer of his properties and business, that such other person or company, shall continue to perform the duties or engagements of the contractor under this contract and be subject to his liabilities there under.
- n.** Interpretation of the contract document: The representative of the GMTD Shimla and the contractor shall in so far as possible by mutual consultation, try to decide upon the meaning and intent of the contract document. In case of disagreement the matter shall be transferred to the CGMT HP whose decision shall be final. Any change in the contract documents shall be set forth in writing by the representative of the parties hereto. It shall be the contractor's responsibility to thoroughly familiarize all of his supervisory personnel with the contents of all the contract documents.
- o.** Notification: - The contractor shall give in writing to the proper person or authority with a copy to the Divisional Engineer such notification as may be mandatory or necessary in connection with the commencement, supervision resumption, performance and/or completion of the contracted work. All notice shall be given sufficiently in advance of the proposed operation to permit proper co-relation of

activities and the contractor shall keep all proper persons or authorities involved and advised of the progress of operations through out the performance of the work and /or with such other information and / or supporting figure and data as may from time to time as directed or required.

- p. Shut down on account of weather conditions. The contractor shall not be entitled to any compensation whatsoever by reason of suspension of the whole or any part of the work made necessary by BSNL or deemed advisable on account of bad wether conditions or other Force Major conditions.

4.2.2

Stores Supplied by BSNL:

- a. All materials supplied to the contractor by BSNL shall remain the absolute property of BSNL and shall not be removed from the site of the work except for use in the work and shall be at all times open for inspection by the representative of the GMTD Shimla. In case the materials like cable and accessories are taken by the contractor and stored at the site office/store of the contractor, such site office / store will also be treated as site for this purpose. Any such materials remaining unused at the time of the abandonment, completion or the termination of the contract shall be returned to BSNL at a place informed to him by BSNL, failing which the cost of the unused materials shall be deducted from the contractor's material security or any of his pending bills or from any other security.
- b. The contractor shall be responsible for the transportation of store, storage and safe custody of all material supplied to him by the BSNL, which are in the contractor's custody whether or not installed in the work. The contractor shall satisfy himself regularly with the quantity and quality of the materials supplied to him and he will be responsible for any subsequent deterioration and discrepancy (inclusive of theft) in the quality and quantity of the materials.
- c. The contractor shall submit a proper account every month of all the materials supplied to him by the BSNL and those consumed for items of work. Any discrepancy or difference between the materials issued to the contractor and those consumed in the work as per the "BSNL's calculation"(which shall be final) will be charged to the contractor or deducted from his bills at 1.5 times of prevailing price including freight, handling charges ,storage charges etc.
- d. The contractor shall ensure that only the required materials are issued to him. Upon completion of work, the contractor shall return to the BSNL at the later, designated store in good condition, free of charges, any unused materials that were supplied by BSNL.
- e. Easements, Permits, Licenses and other facilities: The contractor shall obtain /provide at his own cost all easements, permits and license necessary to do work except for the following which shall be provided by the Representative of the GMTD Shimla.
 - i. "Right of User" easements and permits
 - ii. Railway and Highway crossing permits including bridge.
 - iii. Canal/stream crossing permits.
- f. The contractor shall be fully responsible for angling and obtaining all necessary easements, permits and licenses, for moving all necessary equipments, tools, supplied materials and men across Railways and Highways ,across public or private road as well as premises of any public utility within the right of user and for bearing all costs, that may be incurred in respect of the same.
- g. The contractor is to confine his operation to the provided work "Right of User" unless it has made other arrangements with the particular property owners and /or tenants such other arrangements shall be entirely at the responsibility of the

- contractor as to cost and arrangements as also breach and claim and shall be entitled with a copy to the Divisional Engineer.
- h. The contractor will not be entitled to extra compensation for hardship and increase in cost by the cable trench being routed adjacent to or across other pipeline, Highways, Railways, Telephones, embankments, cliffs, streams or other obstacles which may physically or otherwise in any manner, restrict or limit the use of the Construction Right of User”.
 - i. At location where the HDD/Trench is routed across or along railways or roads the contractor shall without extra cost provide and maintain such detours and road controls as are required by the railways or government or local agencies having jurisdiction.
 - j. If BSNL is not able to provide above mentioned permits etc. then the extension of time limit shall be provided as per EOT clause given in tender document.

4.2.3 Quality of work :

BSNL shall be the final judge of the quality of the work and satisfaction of BSNL in respect thereof set forth in the contract documents. The contractor shall be and remain responsible for complete and proper compliance with the contract documents and the satisfaction therein. The representative of the GMTD has the right to prohibit the use of men and any tools, materials and equipment which in his opinion do not produce work or performance meeting the requirement of the contract documents.

4.2.4 Taxes and duties:

Contractor shall pay all rates , levies, fees, royalties, taxes and duties payable or arising out of ,by virtue of or in connection with and /or incidental to the contract or any other obligations of the parties in terms of the contract documents and /or in respect of the works or operations or any part thereof to be performed by the contractor and the contractor shall indemnify and keep indemnified BSNL from and against the same or any default by the contractor in the payment thereof.

4.2.5 PROTECTION OF LIFE ,PROPERTY AND EXISTING FACILITIES:

- a. The contractor is fully responsible for taking all possible safety precaution during preparation for and actual performance of the works and for keeping the work site in a reasonable safe condition. The contractor shall protect all life and property from damage or losses resulting from his construction operations and shall minimize the disturbance and inconvenience to the public.
- b. If the HDD/open trench work alters the contours of the ground around the road and highway crossing in such locations dangerous to traffic, the contractor shall at his own cost, take all necessary precautions to protect public and shall comply with all BSNL regulations as to placing of warning boards (Minimum size 3 ft. X 2 ft.), traffic signals, barricades, flags etc., at such location. If the contractor does not put the warning signal as per above directions, then a penalty of Rs.5000/- per day shall be levied on the contractor, till the directions are complied by the contractor. The contractor shall take due precautions to avoid damages to other pipe lines, water mains, sewers, telephones, telegraphs and power conduits, laid wires piles and guy wires, railways, highways, bridges or other underground or above ground structure and / or property crossing or adjacent to the HDD/open trench work being done.
- c. Attention of the contractor is drawn to the rules regarding HDD/open trench work at road crossing, along Railway Bridges, Highways safety precautions while working in public street. **The contractor shall execute the work as per latest Engineering Instructions for OFC laying in BSNL .**

- d. The contractor shall be solely responsible for location of existing structure (through approved non-destructive means) and ensuring the safety of all existing underground pipeline, electrical cables and / or other structures.
- e. The contractor shall be solely liable for all expense for and in respect of repairs and/or damage occasioned by injury of or damage to such underground and above structures or other properties and undertake to indemnify BSNL, from and against all actions, cause of actions, damages, claims and demands what so ever, either in law or in equity and all losses and damages and costs (inclusive between attorney and client), charges and expenses in connection therewith and / or incidental thereto. The contractor shall take all responsibilities and risk in crossing other pipelines and cables and shall be responsible for protecting all such existing pipelines, poles, electric lines, sewers, cables or other facilities from damage by the contractor's operation in connection with the work. The contractor without cost of BSNL shall promptly repair any damage incurred.
- f. The current market value of any commodities lost as a result of any damage to the aforesaid existing facilities shall be paid by the contractor together with such additional sums necessary to liquidate the personal of property damages, resulting there from.

4.2.6

Labour Welfare measures and workman compensation

- i Obtaining license before commencement of work :- The contractor shall obtain a valid labour license under the Contract Labour (H&A) Act, 1970 and the contract labour (regulation and abolition) Central rules 1971, before commencement of the work, and continue to have a valid license until the completion of work. The contractor shall also abide by the provisions of the Child Labour (Prohibition and regulation) Act 1986. Any failure to fulfill the requirement shall attract the penal provisions of the contract arising out of the resultant non- execution of work. He will have to supply attested copy of labour license whenever required as per labour laws. The contractor will himself be responsible for all statutory obligations of labour laws & other Acts etc. BSNL Shimla will not be responsible for any violations of labour laws by contractor.
- ii **Labour Regulations :**
 1. Working Hours: Normally working hours of an employee should not exceed 9 hours a day. The working day shall be so arranged that inclusive of interval for rest, if any, it shall not spread over more than 12 hours on any day.
 2. When a worker is made to work for more than 9 hours on any day or for more than 48 hours in any week, he shall be paid over time for the extra hours put in by him.
 3. Every worker shall be given a weekly holiday normally on a Sunday, in accordance with the provisions of minimum wages (central) Rules 1960, as amended from time to time, irrespective of whether such worker is governed by the minimum wages Act or not.
 4. The minimum wages prescribed by the government, under the minimum wages Act, are not inclusive of the wages for the weekly day of rest. The worker shall be entitled to rest day wages, at the rate applicable to the next preceding day, provided he has worked under the same contractor for a continuous period of not less than 6 days.
 5. Where a contractor is permitted by the Divisional Engineer-in-charge to allow a worker to work on a normal weekly holiday, he shall grant a substituted holiday to him for the whole day, on one of the five days, immediately before or after the normal weekly holiday, and pay wages to such worker for the work performed on the normal weekly holiday at the overtime rate.
 6. Display of Notice Regarding Wages etc.

The contractor shall, before he commences his work on contract, display and correctly maintain and continue to display and correctly maintain, in a clear and legible condition in conspicuous places on the work, notices in English and in local Indian languages spoken by the majority of the workers, giving the minimum rates of the wages fixed under minimum wages Act, the actual wages being paid, the hour of work for which such wage are earned, wages and other relevant information.

iii **Payment of Wages:**

1. The contractor shall fix wage periods in respect of which wages shall be payable.
2. The wage period shall not exceed one month.
3. The wages of every person employed as contract labour in an establishment or by a contractor, where less than one thousand such persons are employed, shall be paid before the expiry of seventh day of the following month and in other cases before the expiry of tenth day

after the last day of the wage period in respect of which the wages are payable.

4. Where the employment of any worker is terminated by or on behalf of the contractor, the wages earned by him shall be paid before the expiry of the second working day from the date on which his employment is terminated.
5. All payment of wages shall be made on a working day at the work premises and during the working time and on a date notified in advance and in case the work is completed before the expiry of the wage period, final payment shall be made within 48 hours of the last working day.
6. Wages due to every worker shall be paid to him direct or to other person authorised by him in this behalf.
7. All wages shall be paid in current coin or currency or in both.
8. Wages shall be paid without any deductions of any kind except those specified by the central government by general or special order in this behalf or permissible under the payment of wages Act 1956.
9. A notice showing the wages period and the place and time of disbursement of wages shall be displayed at the place of work and a copy sent by the contractor to the Engineer-in-charge under acknowledgement.
10. It shall be the duty of the contractor to ensure the disbursement of wages in presence of the site Engineer-in-charge who will be required to present at the place and time of the disbursement of wages by the contractor to workmen.
11. The contractor shall obtain from the site incharge / Engineer or any other authorised representative of the Site in-charge, as the case may be, a certificate under his signature at the end of the entries in the "Register of wages " or the "wage-cum-muster Roll", as the case may be, in the following form:-
"certified that the amount shown in the column no..... has been paid to the workmen concerned in ,my presence on.....at....."

iv Fines and deductions which may be made from wages

1. The wages of a worker shall be paid to him without any deduction of any kind except the following:-
 - a. Fines
 - b. Deductions for absence from duty i.e. from the place or the places where by the terms of his employment he is required to work. The amount of deduction shall be in proportion to the period for which he was absent.
 - c. Deductions for damage to or loss of goods entrusted to the employed person for custody, or for loss of money or any other deductions which he is required to account, where such damages or loss is directly attributable to his neglect or default.

- d. Deduction for recovery of advances or for adjustment of overpayment of wages, advances granted shall be entered in a register.
 - e. Any other deduction, which the central government may from time to time allow.
2. No fines should be imposed on any worker save in respect of such acts and omissions on his part as have been approved of by the labour commissioner.
 3. No fine shall be imposed on a worker and no deduction for damage or loss shall be made from his wages until the worker has been given an opportunity of showing cause against such fines or deductions.
 4. Every fine shall be deemed to have been imposed on the day of the act or omission in respect of which it was imposed.

4.2.7 Labour records:

1. The contractor shall maintain a Register of persons employed on work on contract in form XIII of the contract Labour (R & A) central Rules 1971.
2. The contractor shall maintain a Muster Roll register in respect of all workmen employed by him on the work under contract in form XVI of the CL (R&A) Rules 1971.
3. The contractor shall maintain a Wage Register in respect of all workmen employed by him on the work under contract in form XVII of the CL (R & A) Rules 1971.
4. Register of accidents- The contractor shall maintain a register of accidents in such form as may be convenient at the work place but the same shall include the following particulars:
 - a) Full particulars of the labourers who met with accident.
 - b) Rate of wages.
 - c) Sex
 - d) Age
 - e) Nature of accident and cause of accident
 - f) Time and date of accident
 - g) Date and time when admitted in hospital
 - h) Date of discharge from the hospital
 - i) Period of treatment and result of treatment
 - j) Percentage of loss of earning capacity and disability as assessed by medical officer
 - k) Claim required to be paid under workmen's compensation Act
 - l) Date of payment of compensation
 - m) Amount paid with details of the person to whom the same was period
 - n) Authority by whom the compensation was assessed

Remarks

- The contractor shall maintain a Register of Fines in the form XII of the CL (R & A) Rules 1971 The contractor shall display in a good condition and in a conspicuous place of work the approved list of acts and omission for which fines can be imposed.
- The contractor shall maintain a Register of Deductions for damage or loss in form XX of the CL (R & A) Rules 1971.
- The contractor shall maintain a Register of advances in form XXIII of the CL(R & A) Rules 1971.
- The contractor shall maintain a Register of overtime in form XXIII of the CL (R & A) Rules 1971.

5. Attendance card-cum wage slip
 - a. The contractor shall issue an Attendance card cum wage slip to each workman employed by him.
 - b. The card shall be valid for each wage period.
 - c. The contractor shall mark the attendance of each workman on the card twice each day, once at the commencement of the day and again after the rest interval, before he actually starts work.
 - d. The card shall remain in possession of the worker during the wage period under reference.
 - e. The contractor shall complete the wage slip portion on the reverse of the card at least a day prior to the disbursement of wages in respect of the wage period under reference.
 - f. The contractor shall obtain the signature or thumb impression of the worker on the wage slip at the time of disbursement of wages and retain the card with him.
6. **Employment Card**

The contractor shall issue an Employment Card in the form XIV of CL (R&A) central Rules 1971 to each worker within three days of the employment of the worker.
7. **Service certificate**

On termination of employment for any reason whatsoever the contractor shall issue to the workman whose services have been terminated, a service certificate in the form XV of the CL (R&A) central Rules 1971.
8. **Power of labour officer to make investigations or enquiry**

The labour officer or any person authorized by the central government on their behalf shall have power to make enquiries with a view to ascertaining and enforcing due and proper observance of fair wage clauses and provisions of these Regulations. He shall investigate into any complaint regarding the default made by the contractor in regard to such provision.
9. **Report of investigating officer and action thereon:**

The labour officer or other persons authorized as aforesaid shall submit a report of result of his investigation or enquiry to the Engineer-in-charge indicating the extent, if any to which the default has been committed with a note that necessary deductions from the contractor's bill be made and the wages and other dues be paid to the labourers concerned. The Engineer-in-charge shall arrange payment to the labour concerned within 45 days from the receipt of the report from the labour officer or the authorized officer as the case may be.
10. **Inspection of Books and Slips:**

The contractor shall allow inspection of all the prescribed labour records to any of his workers or to his agent at a convenient time and place after due notice is received or to the Labour Officer or any other person, authorised by the Central Government on his behalf.

11. Submission of Returns:

The contractor shall submit periodical returns as may be specified from time to time.

12. Amendments:

The Central Government may from time to time add to or amend the regulations and on any question as to the application/interpretation or effect of those regulations.

13. INSURANCE:

Without limiting any of his other obligations or liabilities, the contractor shall, at his own expense, take and keep comprehensive insurance including third party risk for the plant, machinery, men, material etc. brought to the site and for all the work. The contractor shall also take out workmen's compensations insurance as required by law and under take to indemnify and keep indemnified the Government from and against all manner of claims and demands and losses and damages and cost (including between attorney and client) charges and expenses that may arise in regard the same or that the BSNL may suffer or incur with respect to and/or incidental to the same. The contractor shall have to furnish originals and /or attested copies as required by the BSNL of the policies of insurance taken within 15 days of being called upon to do so together with all premium receipts and other papers related thereto which the BSNL may require.

4.2.8

COMPLIANCE WITH LAWS AND REGULATIONS:

During the performance of the works the contractor shall at his own cost and initiative fully comply with all applicable laws of the land and with any and all applicable by laws, rules, regulations and orders and any other provisions having the force of law made or promulgated by the Government, Governmental agency or department, municipal board, Government of other regulatory or authorised body or persons and shall provide all certificates or compliance therewith as may be required by such applicable law. By laws, rules, regulations, orders and/ or provisions. The contractor shall assume full responsibility for the payment of all contributions and pay roll taxes, as to its employees, servants or agents engaged in the performance of the work specified in the contractor documents. If the contractor shall require any assignee or sub contractor to sham any portion of the work to be performed hereunder may be assigned, sub- leased or sub contracted to comply with the provisions of the clause and in this connection the contractor agrees as to undertake to save and hold the Government harmless and indemnified from and against any/all penalties, actions, suits, losses and damages, claims and demands and costs(inclusive between attorney and client) charges and expenses whatsoever arising out or occasional, indirectly or directly, by failure of the contractor or any assignee or subcontractor to make full and proper compliance with the said by laws, rules, regulations, laws and order and provisions as aforesaid.

End of chapter IV

CHAPTER – V PROFORMA

5 (A) Experience Certificate

Office of ----- (With complete address & Phone no. of issuing authority)

(To whom so ever it may concern)

Certified that M/s -----Complete postal address -----

----- had successfully completed the work of laying of OFC
cable on route ----- to ----- (distance: -----
----- Km) on ----- vide work order no. -----
----- dated -----The payment of Rs. -----
----- had been made to the contractor for this work.

Sign of JAG level Officer or
Equivalent
(With rubber stamp)

(NOTE : This certificate should be issued on Letterhead of the office of issuing authority.)

5 (B) LETTER OF AUTHORISATION FOR ATTENDING BID OPENING

From -----

To-----

Subject: - Authorization for attending bid opening

Tender No -----

Having submitted bid in above tender Following persons viz----- is hereby authorized to attend the bid opening for the tender mentioned above on our behalf his signature is attested below (Bidder) .

Name

Signatures of

Shri-----

Signatures of bidder

Note :Permission for entry to the hall where bids are opened may be refused in case authorization as prescribed above is not recovered.

5 (C) AGREEMENT FORM

The successful tenderer shall have to execute the following agreement :

This agreement made on this _____ day of (Month _____) (year) _____ between M/s _____
_____ herein after called

“The Contractor” (Which expression shall unless excluded by or repugnant to the context, include its successors, heir, executors, administrative representative and assignee) of the one part & the BSNL, of other part. Where as the contractor has offered to enter into contract with the BSNL for the execution of work of trenching & pipe laying by HDD/open trench method, OF cable blowing, OF cable Splicing and termination, Preparation of joint chamber, fixing, painting and sign writing of route/joint indicators and other associated works in the GMTD SHIMLA jurisdiction on the terms and conditions herein contained and the rates approved by the BSNL (copy of Rates annexed) have been duly accepted and where as the necessary security deposits have been furnished in accordance with the provisions of the tender document and whereas no interest will be claimed on the security deposits.

Now, in the presence of the witness, it is hereby agreed and declared by and between the parties as follows :-

- 1) The contractor shall, during the period of this contact that is to say fromtoor completion of work for Rs _____(in words) _____whichever is earlier or until this contact shall be determined by such notice as is hereinafter mentioned, safely carryout, by means of labours employed at his own expenses and by means of tools, implements and equipment etc. to be supplied by him to his labour at his own expenses, all trenching (HDD/open trenching), pipe laying, cable blowing, joint chamber preparation, fixing, painting and sign writing of route indicators and other associated work as described in tender documents (annexed to the agreement), when the BSNL or (the GMTD SHIMLA) or any other persons authorized by the GMTD SHIMLA in that behalf require. It is understood by the contractor that the quantity of work mentioned on the schedule is likely to change as per actual requirement as demanded by exigencies of service.
- 2) The NIT (Notice Inviting Tender), Bid document, letter of acceptance, approved rates, annexed hereto and such other additional particulars, instructions, drawings, work orders as may be found requisite to be given during execution of the work shall be deemed and taken to be an integral part of the contract and shall also be deemed to be included in the expression “The Agreement” or “The Contract” wherever herein used.
- 3) The contractor shall also supply the requisite number of workmen with means & materials as well as tools, appliances, implements, vehicles for transportation, cartage etc. required for the proper execution of work within the time prescribed in the work orders.

- 4) The contractor hereby declares that nobody connected with or in the employment of the BSNL is not/shall not ever be admitted as partner in the contract.
- 5) The contractor shall abide by the terms and conditions, rules, guidelines, construction practices, safety precautions etc. stipulated in the tender document including any correspondence between the contractor and the BSNL having bearing on execution of work and payments of work to be done under the contract.

Above written:

Signed sealed & Delivered by the above named Contractor in the presence of

Witness:

1.

2.

Signed & Delivered on behalf the BSNL the

Witness:

5(D) Work Order Format

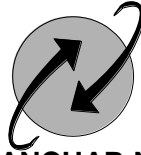

BHARAT SANCHAR NIGAM LIMITED
(A Govt. of India Enterprise)
Office of the GMTD Shimla Block No. 35
SDA Complex Kasumpti, Shimla- 171 009
Phone No. 0177-2626344

Work Order No.:

Dated the

To,

M/s -----

Sub: Laying of OF Cable in PLB Pipe duct underground.

Ref : Tender no

1. Name of the route :
2. Length of Route :
3.
 - a. Date of commencement :
 - b. Date of Completion
(Total Days : -----)
4. Name of Site in charge (SDE) : -----
5. Name of Store Site -----

AGM (Planning)

End of chapter V

Note- It can be any standard performa of GMTD office

CHAPTER VI

SCOPE OF WORK AND WORK SPECIFICATION (Open Trench)

Specification of work for laying of OF Cable in PLB HDPE Pipe Coil underground duct along with its construction & associated works.

Section A

- 6.1 General:** - In order to provide connectivity between telephone exchanges or otherwise OF Cable is required to be laid. The OF Cable is usually laid under ground but may be required to be laid aerially on telephone post especially in hilly area depending on site conditions.
- 6.1.1 The OF Cable shall be laid in PLB pipe coil duct abbreviated as PLB Pipe henceforth. The PLB pipe shall be of 40 mm & 33 mm outer & inner dia respectively.
- 6.2 SCOPE OF WORK:** - The work of lying of Optical Fibre Cable in PLB HDPE Pipe Coils underground duct along with its construction shall involve following activities.
- a) Marking of route on ground where PLB pipe is to be laid underground & obtaining permission from concerned authorities.
 - b) Excavation of trench up to specified depth along National/ State Highways/ other roads including those in city limits
 - b1) Laying of PLB pipe Coils (without or with PP rope as specified in tender information) coupled by HDPE sockets in excavated trenches.
 - b2) The PLB pipe shall be sealed by end cap at every hand hole/ Jointing Chamber
 - b3) Fixing of GI pipes/ troughs with clamps at bridges/ culverts and/ or concreting or chambering of G.I. Pipes/ troughs, wherever necessary.
 - b4) Providing of mechanical protection by RCC Split Pipes/ GI pipes and/or concreting/ chambering according to construction specifications, wherever required.
 - b5) Back filling and dressing of the excavated trenches.
 - c) Making hand holes/ Jointing/ Man hole chambers en route.
 - d) Pulling of OF cable in PLB pipe duct with PP rope with proper tools & accessories.
 - d) Splicing/ Jointing of OF cable.
 - e) Leading in of OF Cable in the exchange premises.
 - f) Supply, fixing & painting of Route/ Joint indicators.
 - g) Dismantal of AOFC and posts in case of conversion of AOFC to U/G.
 - h) Documentation.

6.3 ALLIED ACTIVITIES:

6.3.1 **Permission from Authorities:** The contractor shall accord necessary help in obtaining permission from Local municipality, NHAI, Rail and forest authority. The cost of providing help in obtaining permission are subsumed in the standard scheduled rates and therefore no separate charges are payable on this account. However, the Charges payable to the Authorities shall be borne by BSNL.

6.3.2 **Transportation of Materials:** The materials required for executing the work entrusted to the contractor against a work order shall be made available at SSA Store Depot Bhattakufar. The contractor shall be responsible for transporting the materials, to be supplied by the BSNL or otherwise to execute the work under the contract, to site at his/ their own cost. The costs of transportation are subsumed in the standard Schedule Rates and therefore no separate charges are payable on this account.

6.3.3 **Supply of Materials:** There are some materials required to be supplied by the contractor for execution of work under this contract like Concreting material, RCC Split pipe, Cement, Wire Mesh and joint indicators, etc. The contractor shall ensure that the materials supplied are of best quality and workmanship and shall be strictly in a accordance with the specifications.

6.3.4 **Empty Cable Drums:** The contractor shall be responsible to deposit the empty cable drums after laying of the cables in Store depot.

6.4 **Method of measurement:** The measurement of the work shall be done for activity-wise as and when the item of work is ready for measurement. The methods of measurement of various items are enumerated as under:

6.4.1 Measurement of depth of trenches

The measurement of depth shall be recorded at each point of measurement (POM) in the measurement book in meters in the multiples of 5 cms. For example 97 cms will be recorded as 95 cms And 103 cms as 105 cms. The points of measurements shall be at a distance of 10 meters starting from 0 (Zero) meter. For example, if the length of segment is 75 meters, the POMs shall be at 0 M, 10 M, 20 M, 30 M, 40 M, 50 M, 60 M, and 70 M. The last POM shall be at 75th M to be recorded against residual POM.

If water drain or road gutter encountered along the road the depth shall be measured from the top surface of the water drain or road gutter. However, payment will not be made for the undug portion in the water drain or road gutter. The efforts required to excavate trenches is not proportionate especially with reference to depth. Therefore, normally the workers tend to dig shallow trenches. As standard depth of the trench is important for future life and protection of cables, this tendency has to be discouraged. In order to encourage the contractor to achieve best possible depth in the face of site constraints, the following scale of payment shall be applied for digging trenches of lesser depths, subject to condition that relaxation has been granted by the competent authority for lesser depths. No payment will be made for depth below 30 cm.

A) DEPTH OF TRENCH 165 Cms for all type of soil

Depth between	Reduction in rate
<140 Cms. to >= 135 Cms.	05% of approved rates
<135 Cms. to >= 120 Cms.	15% of approved rates
<120 Cms. to >= 105 Cms	25% of approved rates
<105 Cms. to >= 90 Cms	35% of approved rates
Below 90 cms.	40% of approved rates

6.4.1.2 The payment for subnormal depth will be calculated as per formulae given below:-

$$P = (100 - ROR) \times RA \times D / ND$$

P = Payment for one meter

ROR = Reduction in rate in % as given above

RA = Approved rate of trenching per meter

D = Actual depth in m.

ND = Nominal depth of trench 140 cms. for which the tender has been floated.

6.4.1.3 Competent authority for granting less depth relaxation

Depth	Concerned officer	Protection
Up to 120 cms	Divisional Engineer in Charge	Without protection or as per site condition.
Up to 90 cms	GMTD Shimla On recommendation of Divisional Engineer in-charge.	As per site condition , DWC or RCC Pipes can be used
Less Than 90 cms to 60	CGMT HP Circle Shimla	DWC or GI up to 70 cms as decided by Engineer-in-charge. CC or GI pipe for less than 70 cms or as recommended by Site inchargeaspersite requirement.
Below 60	Depth is not acceptable except on Bridges.	On Bridges GI should be laid and their ends must be sealed with concreting.

6.4.2 Measurement of lengths and profiles of strata and protection

The measurements of length of trenches are on running meter basis, irrespective of type of soil encountered while digging.

The type of protection provided (item code – wise) in a segment shall be recorded in the measurement book in the sheet provided for this purpose.

6.4.3 Measurement of length of PLB pipe: - The length of PLB pipe laid in trenches shall be measured by use of RODO Meter/ Measuring Tape. The lengths shall be recorded in sheet provided in the measurement book.

6.4.4 Measurement of other items: The measurement/ numerical details of other items shall be recorded in the sheets provided for respective items viz.

- Digging of joint pit and preparation of joint chamber along with its type i.e. Brick chamber or Pre Cast RCC type.
- Fixing, Painting and sign writing of route/joint indicators
- Termination of Cable in equipment room and no. of joints.

6.4.5 The contractor shall sign all the measurement recorded in the measurement book. This will be considered as an acceptance by the contractor, of measurements recorded in the MB. In case contractor fails to attend at the measurements or fails to countersign or to record the difference with in a week, than in any such events the measurements taken by Engineer-in-charge or by the subordinate as the case may be shall be final and binding on the contractor and the contractor shall have no right to dispute the same.

- 6.4.6 The Divisional Engineer before passing the bill for sections covered by each set of measurement may carry out test check by re-opening trench at as many locations as necessary as specified in document procedures for underground cable construction' and bills will be passed only when he is personally satisfied of the correctness of entries in the "measurement Book" and also when he is satisfied of other aspects of the work as per the terms of the contract. The contractor shall provide the necessary assistance of labour for re-opening of trench for test check by the Divisional Engineer. Separate payment shall not be made to the contractor for excavation of such test checks, however such test pits shall not be more than 10% of the cable laying work.
- 6.4.7 Measurement of the work of cable pulling through pipe/duct will be taken equal to the length of the pipe/ duct through which the cable has been pulled and not the total length of the cable pulled through pipe/duct.

6.5 PLB PIPE LAYING Practices through HDD Method :

6.5.1 Trenching and Insertion of PLB Pipe:

The work includes three sizes of horizontal boring for insertion of either '1', '2 / 3' or '4 to 7' number of PLB pipes along road and under railway/road/canals/streams crossing in all type of soils at prescribed depth, including all civil works & reinstatement as per standards, supply of lifting tools and tackles other required equipment and consumable, labour etc., and making all such necessary arrangements for completion of work.

The HDD location (entry and exit points of bore) markings shall be given by the site engineer. The contractor has to remove the interlocking blocks, foot path stones and / or the foot path dividers (iron railings) in order to keep the HDD machine. At the entry and exit points, pits have to be taken to a depth of at least 2.0 m. As per the marking of the site engineer, the boring shall be done. After the bore reaches the exit point on the remote pit, the site engineer, shall record in Measurement Book, the depths enroot, every 5 meters and the alignment (offset). If the site engineer is satisfied with the depth, the pipes are inserted and the bore is pulled back.

The PLB pipes are supplied in the coil form. Before laying, they should be de-coiled and laid parallel on the ground. The pipes should be properly formed so that there is no coiling tendency for the pipes. The number of pipes to be laid will be indicated by the site engineer, and shall be bundled and tied every 2 meters with a tie. The pipes shall be brought above surface in the entry pit and end plugs are fixed tightly. In the exit pit, the excess pipe is cut and the end plugs are tightly fixed. In case duct laying is completed on the other side, these pipes shall be connected to the existing ducts through couplers. After the boring work is completed, the pit shall be closed and the foot path shall be restored to original form. The bore size shall be made as per the requirement of no. of pipes to be laid on the route which shall be limited to a maximum of 7 nos.

6.5.2 In this system of cable laying, following job specifications should be maintained:

- a) Guided boring/drilling technology is to be used
- b) Radio or any other detection system should be used for avoiding damage to existing underground utilities
- c) The depth of boring should be such as to clear any underground utilities/obstacles. However, in no case the depth of boring be less than 1.7 m, from the road surface
- d) In Horizontal and Vertical boring, the system should be capable of going up to 5 meter below the ground level.
- e) The span of HDD (shot length) will be decided by the Divisional Engineer-in –charge as per the site requirement.

- f) The Contractor should provide sufficient Metal Barricades, Warning Lamps, Display boards indicating
- i) Name of the Contractor
 - ii) Organization : BSNL
 - iii) Contact Number, at the work site.

6.5.3 Ground Penetrating Radar Survey (GPRS) and damage to Telephone Cable and other underground services. Ground Penetrating Radar Survey (GPRS) shall be done by the contractor at his own cost to identify and prevent damage to Telephone Cables and other underground services such as Water line, Sewage system, electricity cable etc. The contractor will be responsible for all damages caused to the underground utilities and the compensation claimed by the service provider should be paid by the contractor failing which the same will be adjusted against any amounts due to the contractor, including running/ final bills of this work.

6.5.3.1 The contractor should collect all available information regarding underground services and take necessary care to protect them. He should also have sufficient arrangements to identify and protect such underground services.

6.5.3.2 The contractor shall carry out GPRS along the proposed cable route at his own cost to identify the underground services and for setting out the routes as directed by Site Engineer. The Site Engineer shall provide route map to the contractor if available for plotting the existing utilities and setting the route for horizontal drilling.

6.5.3.3 At the time of completion of work, the records of actual route/depths of cable laid is to be transferred to the Site Engineer along with other necessary documents and drawing. The record of depth should be given at the interval of 5 meters.

6.5.3.4 Reinstatement of road surfaces

For any excavation done in the public property , the tenderer has to bring the same to the original form of surface, as per technical specification of Local authorities. All the reinstatement will be subjected to inspection of BSNL and Local authorities or any such agency as and when decided. If the quality of the reinstatement is found to be unsatisfactory, penalties as applicable will be payable by the contractor.

6.5.3.5 Time frame for carrying out the works

The contractor is expected to carry out at least 100 meters of Trenching including pipe laying works in a day.

6.5.3.6 Preparation of Documents.

The documents should be prepared by the contractor in the spiral bound sets which will contain the following :

The route diagram should indicate the road, Hand holes(joint chambers), Number of Pipes, Important land marks in one sheet.

The detailed profile of the Horizontal Boring route to the scale of 1cm : 2 m to be drawn in A4 sheet indicating the following details:

- a) The offset – every 10 m interval
- b) Land marks – minimum one per 30 m
- c) The depth of the boring profile – every 5 m interval
- d) Hand holes
- e) Number of Pipes / Cables and colour.
- f) Other utilities running parallel or crossing the route.

6.5.3.7 The documents should be prepared in computer using drawing tools of MS Office and six bound sets should be made over along with a soft copy. The drawings will be accepted by the Site Engineer after verifying the correctness, usability.

6.6 Tools and plants:-The contractor shall make available at his own cost all tools, plants appliances, implements etc. required for proper execution of works. The contractor shall also supply without charge the requisite number of persons with the means and materials necessary for the purpose of setting out works, counting, weighing and assisting the measurements for examination at any time and from time to time.

The contractor shall be responsible to make all arrangements, at his own cost for de-watering of trenches/ducts and de-gasification of the ducts before carrying out the work. The contractor shall also be responsible to make arrangements, at his own cost, for water required for carrying out of works at sites including curing of CC/ RCC works. Failing his so doing the same may be provided by the Engineer-in-charge at the expense of the contractor and the expenses shall be deducted from any money due to the contractor under this contract or otherwise.

6.7 Test & Inspections:-

Test & inspections of the completed duct system shall be carried out. Upon final acceptance testing and inspection (in stages if desired by BSNL) of the installed works, the contractor shall make over the same to Engineer-in-charge, after rectification of defects, if any.

a) Instructions to contractors & precautions to be taken: The contractor/ authorized representative shall always be available at the site during the progress of work to take instruction from Engineer-in-charge or his representative. The contractor shall display at the site prominently the name and address of representative who can be contacted in case of emergency.

b) In case local authorities insist for trenching during night, trenching activities will be restricted to night hours and no open trenches will be left during day hours.

c) The Work shall be executed so as to cause minimum interference to road traffic and pedestrians. Suitable arrangements shall be made for providing passage to pedestrians and vehicles. The inconvenience to the public shall be remedied at the risk and cost of the contractor/agency and decision of Engineer-in-charge shall be final and binding. The contractor shall provide and maintain sufficient caution-cum-information boards, warning tapes and adequate barricading with lighting arrangement, as required along excavation work areas as per requirement of the code of conduct for public utility for better road maintenance in the concerned city/state. Required no. of men shall be provided by the contractor at his own cost to control traffic, prevent any accidents to pedestrians or vehicles. Any violation of these guidelines, if it attracts any levies/damages, shall be borne by the contractor. Caution-cum-diversion board of reflector type shall be provided at each end of trench to caution the traffic and during dark hours, lights shall be operated at site. In the event of failure in observing the above mentioned precautions, BSNL shall provide warning boards, tapes, cones, barricading etc., at its discretion and debit the cost to contractors account. However this shall not absolve the contractor from his responsibilities and liabilities. In addition, the contractor shall be liable for the levy of fine not exceeding Rs. 5000/- (Rs. Five Thousand Only) on a single occasion. The decision of Engineer-in-charge in respect of the defaults by the contractor and the amount of fine shall be final & binding. In case of repeated imposition of fine on three occasions, the contractor would be liable for penal action including termination.

- d) All steps shall be taken to prevent damage to paving outside excavation areas & restore the same if damaged, at contractors cost and to protect paving form contamination by fuel and/ or oil from the equipment used at site.
- e) Any useful material obtained from the excavation shall be stacked separately and shall be the property of BSNL/ Local bodies and shall be disposed off as per directions of Engineer-in-charge.
- f) Where pneumatic drills or other power driven road breaking appliances are used, they shall be fitted with silencing devices and the compressor machine shall be maintained in an efficient condition to avoid undue noise.

6.8 SPECIFICATION FOR CONCRETING

- a) The nominal dimension of concreting shall be instructed by Site Engineer during the execution of work. Depending on the situation at site and
- b) number of the pipes to be laid/ used, the cross sectional dimension may vary to ensure proper protection to the pipes as well as uniformity with any existing structure based on which the GI Pipes are placed as demanded by the road authorities.
- c) At both the ends of the Bridges/ Culverts where the GI pipes slope down and get buried, the concreting shall be carried out to ensure that no portion of GI Pipe is exposed and further down as required by the site Engineer to protect the Pipe from any possible damage.
Any damages caused to the existing structure such as foot path or base of the parapet or kerb wall on which GI pipes are placed shall be repaired and original condition restored to the satisfaction of Road Authorities.
- d) The Contractor shall provide all the material required for the cement concreting work at the site. Cement concrete Mixture used shall be of 1:2:4 composition i.e. 1 Cement, 2. Coarse Sand, 4. Graded Coarse Stone aggregate of 20 mm nominal size. Smooth finishing of exposed surface shall be done with a mixture of 1:3 i.e. 1. Cement 3. Fine Sand.
- e) Portions where cement concreting have been done shall be cured with sufficient amount of water for reasonable time to harden the surface. After curing, refilling of the balance depth of the trench has to be done with excavated soil. It may be noted that no extra payment is admissible for arranging material, labor tools and machine while carrying out the work.

6.9 STORES TO BE PROCURED BY THE CONTRACTOR

- a) The items to be procured by the contractor will include the following:
 - i) River Sand
 - ii) Construction material steel, cement, jelly, sand etc., for concreting works.
 - iii) Warning boards, warning tape, warning cones, flags, signals, barricades, electric warning lamps and bands.
 - iv) Any other material used in this work.
- b) All materials for use shall be new and duly tested as per approved standards and shall comply the material specifications. Where no spec is specified, it shall conform to BIS/ISI/CPWD standards.
- c) The stores procured by the contractor will be tested for meeting standards prescribed and only such material which meets the standards will be accepted and allowed to be utilized. This does not absolve the contractor from his responsibility to replace and redo the work in case of failure of the construction during 1 year from date of completion of construction.

6.10 SPECIFICATION FOR STONE AGGREGATES, COARSE SAND, FINE SAND:

- a) **Stone aggregate:** Stone aggregate to be used in the work shall be hard broken stone and shall conform to CPWD specification 1996 volume II
- b) **Coarse sand:** Coarse sand to be used shall conform to CPWD specification 1996, Volume II.
- c) **Fine sand:** Fine sand for finishing to be used in the work shall conform to CPWD specifications 1996 Volume II.

Note: Where only one variety of sand is available, the sand will be sieved for use in finishing work as directed by the Engineer-in-charge in order to obtain smooth surface and nothing extra will be paid on this account.

6.11 PRELIMINARY INSPECTION:

- a) Before offering completed works for acceptance testing to Engineer-in-charge, the contractor shall complete all checks and tests as required and submit report.
- b) The Site Engineer, Engineer-in-charge and the officers of BSNL including A/T personnel will inspect the work from time to time during the course of construction. The Engineer-in-charge will also conduct a preliminary inspection before offering for acceptance testing and any defects pointed out shall be rectified forthwith at contractor's expense.
- c) In case the completed duct system do not pass the final acceptance testing or checks as required, the contractor shall bear all costs in this regard and re-offer works after rectification for preliminary inspection of the Engineer-in-charge.

6.12 OFFSET DIAGRAM:

Preparation of 3- dimensional offset diagram showing depth, offset from center & edge of road, road boundary, permanent structures, cross-sectional views, details of all important buildings, landmarks etc., City maps and street details to be incorporated. The offset diagram shall be prepared on computer and 3 hard copies (in book form in good quality executive bond paper & printed on inkjet/ laser printer with 600 dpi or higher resolution, and wherever colour printout is required the same should be provided.). Any corrections required will be incorporated before handing over the final copies. The contractor will prepare and hand over the offset diagrams along with floppies containing the drawings to the Engineer-in-charge before acceptance testing.

6.13 FINAL INSPECTION AND A/T:

The Site in-charge/ Engineer after his satisfactory preliminary inspection shall offer the works for final inspection to the Acceptance Testing Unit (hereinafter called A/T Unit). The route index/ offset diagram should be prepared by the contractor and made over to the A/T unit in advance. The A/T unit will randomly check depth, prescribed protection, construction of chambers etc.

The A/T Unit and Site Engineer shall jointly inspect completed section and satisfy themselves that the work has been completed and passed all the checks and test prescribed in Acceptance Testing Schedules.

The inspection resulting in defect free ducting as inspected / Tested above shall be termed as final inspection.

After completion of final inspection, the acceptance-testing unit shall issue the completion and testing reports in prescribed proforma. The A/T, completions Report shall be issued only after all the points have been attended to. The report shall normally be released within 30 days from receipt of offer by the Site Engineer.

No work shall be treated as complete until acceptance testing and quality control checks are completed and found satisfactory. All the defects pointed out by the A/T unit or/and Engineer-in-charge shall be rectified and got re-tested by the contractor at his own cost before the work is treated as completed. The responsibilities of non-clearing the defects and thus non-completion of work shall always rest with the contractor. The rejection of the work shall be intimated to all concerned to ensure prompt action.

All material, equipment, labour and assistance required by Engineer-in-charge A/T Unit for preliminary testing of final A/T shall be provided by the contractor at his own cost.

The A/T report, offset diagrams and M-Book shall constitute the basic records of ducts to be maintained by the BSNL.

At the time of completion of work, the records of actual depths of cable at which it is being laid is to be transferred to the Engineer-in-charge along with other necessary documents and drawing. The record of depth should be given at the interval of 5 meters.

6.14 **OBSTRUCTIONS:**

- a) The obstructions generally come in the form of (1) water mains, sewer pipes or electric cables going across the way of duct, (2) Pillar foundations or foundation of large buildings near by, (3) Roads in close proximity of the routes. They have to be overcome before the trench route can be completed. They may be overcome by giving minor bends to the ducts, in case it is not possible to go through.
- b) Arrangements for negotiating the obstructions should be worked out well in advance to complete the work in time. The work to be carried out by other utilities for shifting their plants should be envisaged well in advance. Simultaneous work saves a lot of time and repeated digging.

Encl.: Annexure- 1 & 2.

Annexure-1

A) List of material to be supplied by BSNL

1. PLB HDPE pipe
2. HDPE coupler
3. End Cap.
4. OF Cable 12 F or 24 F.
5. Joint Enclosure for OF Cable.
6. GI Pipe
7. Any other material not listed for supply by contractor.

Annexure-2

B) List of material to be supplied by Contractor.

1. Material for CC & RCC work viz. Cement, Sand, Aggregate, GI wire
2. Clamps for fixing GI pipe on bridge parapet wall.
3. Pre cast RCC chamber complete.
4. Painting Material
5. RCC Split pipes

Section B: - Optical Fiber Cable Construction Practices.

The guidelines in the form of Engineering Instructions (E.Is.) on Construction Practices of Optical Fiber Cables are issued by T & D Circle of BSNL. The present practices are summarized here from the point of view of describing scope of work under various items of work.

6.1 Planning of OF Cable Route:-

The Optical Fibre Cable route is planned considering the following objectives.

- a) Minimum possible route length vis-à-vis route having maximum number of towns with potential telecom growth.
- b) Linking of small exchanges off main road by leading in O.F.C. vis-a vis routing the main cable itself via such exchanges.

6.1.1 After deciding above issues, a detailed measurement of lengths of cable route along with details of rail/road crossings, culverts, causeways, etc. is recorded in the detailed survey register. The probable locations of joints, terminations and regenerators is also decided and marked on the route map.

6.1.2 On the basis of surveys, general permission from road and rail authorities for laying the Optical Fibre Cable along the decided routes and permission for rail / road crossings will have to be obtained. Generally, O.F.C. is laid straight as far as possible along the road near the boundaries, away from the burrow pits. The O.F.C. is laid along the roads at a minimum distance of 15 meters from the centerline of the road or in accordance with the permission from the concerned road authorities in view of their road-widening plan. As the O.F.C. carries high capacity traffic and is planned for 40 years of life, it is imperative that the cable is laid after obtaining due permission from all the concerned authorities to avoid any damage to the cable and/ or demand for its shifting at a later stage. This may result in disruption of services & thereby revenue loss.

6.1.3 In special cases, where it may be necessary to avoid burrow pits or low lying areas, the cable may be run underneath the shoulder of the road at a distance of 0.6 meter from the outer edge of the road embankment provided the same is located at least 4.5 meters away from center line of road and 1.2 meter below the road surface.

6.1.4 The Optical Fibre Cable is laid through PLB Pipes buried at a nominal depth of 165 cms.

6.1.5 The work of laying of OF Cable in PLB pipe coil underground duct involves following activities.

- a) Excavation of trench up to a nominal depth of 140 cms. Along National/ State Highways/ other roads including in city limits .
- b) Laying of PLB pipe coils coupled by sockets in excavated trenches, on bridges and culverts, drawing of 6 mm polypropylene rope (P.P. rope)
- c) through the PLB pipe coils and sealing of PLB pipe ends at every manhole by end caps of suitable size.
- d) Providing of mechanical protection by R.C.C. Pipes/ GI pipes and/or concreting/ chambering, wherever required.
- e) Fixing of GI pipes/ troughs with clamps at culverts/ bridges and/or chambering or concreting of G.I. Pipes/ troughs, wherever necessary.
- f) Back filling and dressing of the excavated trenches.
- g) Opening of manholes (of size 3 meters x 1 meters x 1.65 meters depth), replacing existing 6 mm P.P. rope by 8 mm P.P. rope (from manhole to manhole) for ensuring smooth passage for pulling the cable. Pulling of Optical Fibre Cable with proper tools and accessories as per construction specifications. Sealing of both ends of the manholes by hard rubber bush of suitable size to avoid entry of rodents into the PLB pipes, putting split HDPE pipes and split RCC pipes with proper fixtures over cable in the manhole to protect the bare cable in the pulling manhole. Back filling and dressing of manholes.
- h) Digging of pit of size 2 meter x 2 meter x 1.8 meter (depth) for construction of jointing chamber at approximately every two kilometers of internal size of 1.5 meter x 1.5 meter x 1.2 meter using bricks and mortar or fixing pre-cast jointing chamber of internal diameter of 1.2 meter filling of jointing chamber with clean sand, placing either pre-cast RCC cover or stone of suitable size on jointing chamber to protect the joint and back filling of jointing chamber with excavated soil.
- i) Digging of pits 1 meter towards jungle side at every manhole and jointing chamber to a depth of 60 cms., fixing of route Indicator/joint indicator, concreting and back filling of pits. Painting of route indicators with yellow colour and joint Indicator by red colour and sign writing denoting route/joint indicator number, as per construction specifications.

SUMMARY OF LAYING PRACTICE FOR OPTICAL FIBRE CABLE

S.No.	Depth (In Centimeters)	Type of Protection required	Remarks
1.	upto 89cms	Concreting reinforced with weld mesh	
2.	89cms to 119cms	DWC/RCC split pipe of approved specification	
3.	120cms to 140cms	No Protection is required	

**The relaxation in laying of OFC for depth from 90cms to 165cms can be granted by GMTD Shimla on recommendation of DET concerned.

**The relaxation in laying of OFC for depth below 90cms can be granted by CGMT HP telecom circle Shimla on recommendation of GMTD Shimla.

S.No.	On culvert/bridges/Rail /Road crossing.			
1.	Nullah dry for nine months in a year.	1.5M below the bed of Nullah.	HDPE pipe in side RCC pipe	As per detail in Fig 4(a).
2.	On culvert / bridges /over other nullahs.	No particular depth specified.	Various options are available as depicted in Fig.4 (a) to 4(g)	The laying is done as per direction of Engineer in-charge.
3.	Rail bridge /crossing	1.5M	HDPE pipe in side cast iron pipe	As per detail in Fig 3(b).
4.	On road crossing	1.5M	HDPE pipe inside RCC pipe /GI pipe	The laying is done as per direction of Engineer in-charge.

- j) All efforts should be made to achieve maximum depth. However in hard and rocky soil minimum acceptable depth should not be less than 30cms. The site engineer should satisfy himself that depth can not be achieved more than that he is recording. The permission of competent authority will be required to be taken.

6.2. Materials used for OF Cable work & their Specifications:

6.2.1 PLB HDPE PIPE COILS

The Optical Fibre Cable is pulled through 40 mm outer diameter Pipe Coils. Of either 1 Km. or 200 meters coil, should meet the specifications as given in GR no. G/CDS-OS/01 Dated December 1994 and revised up to date.

6.2.2 PP Rope

6 mm PP rope is drawn through the PLB pipe coils and safely tied to the end caps at either ends with hooks to facilitate pulling of the OF cables at a later stage. The PP rope used is 3 strands Polypropylene Para Pro rope having yellow colour and shall be of 6 mm diameter and it should have a minimum breaking strength of 550 kgs. The length of each coil of rope should be 205 meters and it should conform to (i) BS 4928 Part-II of 1974 (ii) IS 5175 of 1982 (iii) It should be of special grade and should have ISI certificate mark (iv) It should be manufactured out of industrial quality Polypropylene.

6.2.3 HDPE Socket

For coupling PLB pipe coils, HDPE sockets as per IS 4984-1995 ('O' ring type) made of High Density Polyethylene 5010 or equivalent injection grade material should be used. The HDPE sockets should be black in colour and should be fitted with hard rubber rings at both ends and should conform to GR No. G/CDS-05/01 dated December, 1994 and revised up to date. 5mm x 5mm projections inside at a centre of the socket should be provided to prevent the pipes from passing through. It should weigh 150 gms. (With a tolerance of +/-5%) and should be able to withstand a pressure of 10 kg per sq. cms. without any damage/ deterioration in performance. (**See figure '1' for details**)

6.2.4 **HDPE end caps**

For pulling the cable through the pipes, it is necessary to have suitable manholes at every 200M length and also at bends and corners suitably located. The pipes are laid for 200M or less at a time for the distance between two manholes. The ends of the HDPE/PLB pipe coils are closed with HDPE End Caps. The end caps used should be suitable for closing 50mm outer diameter class V HDPE/PLB pipes. The end cap should be manufactured from High Density Polyethylene, should withstand internal pressure of 10 kg per sq. cms., should be black in colour, should have a weight of 100 gms. (With a tolerance of +/-5%) and should conform to G/CDS-05/01 dated December, 1994 and revised up to date. (See figure '2' for details). A suitable arrangement should be provided in the End Cap to tie PP Rope.

6.2.5 **RUBBER BUSH**

To prevent entry of rodents into HDPE/PLB pipes, the ends of HDPE/PLB pipes are sealed at every manhole and joint using rodent resistant hard rubber bush (cap) after optical fibre cable is pulled. The rubber bush should be manufactured from hard rubber with grooves and holes to fit into 50 mm HDPE/PLB pipe (class V), so that it should be able to prevent the entry of insects, rodents, mud, and rainwater into the HDPE/PLB pipe. It should weight 150 gms (with a tolerance of +/- 5%. It should conform to specification No. G/CDS-05/01 dated December. 1994 and revised up to date. (Please see **Figure No. 3**).

6.2.6 **MATERIALS FOR MECHANICAL PROTECTION**

For lesser depths requiring mechanical protection as per specifications and in built up areas, in towns and cities falling within the municipal limits, suitable mechanical protection is provided to HDPE/PLB pipes/coils using RCC full round/split RCC pipes or GI pipes or concreting of size 25 cms x 25 cms reinforced with MS weld mesh or a combination of any of these as per the written instructions of the Engineer-in-charge.

a) **RCC FULL ROUND PIPES**

Reinforced cement concrete pipes (spun type) coupled with RCC collars sealed with cement mortar are used to provide mechanical protection to HDPE/PLB pipes/coils. The RCC pipes/collars should be of NP-2 class for 100 mm /150mm (internal diameter) full round, conforming to IS standard 458-1988 revised up to date. The pipes should have a nominal length of 2 meters.

The RCC collars should be properly sealed using cement mortar 1:3 (1:53 grade cement of reputed brand, 3: fine sand without Impurities). If the mechanical protection is provided by RCC pipes, every third joint will be embedded in a concrete block of size 60 cms (L) x 40 cms (W) x 25 cms (H) of 1:2:4 cement concrete mix 1:2:4 (1: cement, 2: coarse sand, 4: stone aggregate of 20 mm nominal size) so that the alignment of RCC pipes remain firm and intact. Both ends of RCC / GI pipes will be sealed by providing concrete block of size 40 cm (L) x 40 cm (W) x 25 cm (H) of 1:2:4 cement concrete mix to avoid entry of rodents.

b) **RCC FULL SPLIT PIPES**

Reinforced cement concrete pipes (spun type) with in-built collars are used to provide mechanical protection to HDPE/PLB pipes/coils. The RCC pipes should be of 100mm internal dia.(Spigotted), Class—NP-3, Thickness: 25mm, Length: 2 Meters with inbuilt collar at one end, Conforming to ISI Specification IS: 458, 1988 with latest amendment

c) **G.I. PIPES**

G.I. pipes should be of medium duty class having diameter of 65 mm./40mm. The G.I. Pipes should conform to IS 554/1985 (revised up to date) IS 1989 (Part-I), 1900 Sockets (revised up to date) & IS 1239 (Part-II) 1992 (revised up to date). Wherever protection by G.I. pipe is provided, it is preferable to use HDPE coils. As space on parapet wall on Bridges/culverts is limited, 40 mm GI pipes may be used with 32 mm HDPE coil drawn inside.

d) **M.S. WELD MESH**

The HDPE/PLB pipes can also be protected by embedding it in concrete of size of 25 cms x 25 cms reinforced with MS weld mesh. The MS weld mesh used should be of 50 mm x 100 mm size, 12 SWG, 120 cms in width in rolls of 50m each. One meter of MS weld mesh caters to approx. 3 meters of concreting. (See figure '3' for details)

The strength of RCC/CC is dependent on proper curing, therefore, it is imperative that water content of CC/RCC mix does not drain out into the surrounding soil. In order to ensure this, the RCC/cc work should be carried out by covering all the sides by yellow PVC sheets of weight not less than 1 kg per 8 sq.m. to avoid seepage of water into the soil.

6.2.7 JOINT CHAMBER

The joint chamber is provided at every joint normally at a distance of 2 kms to keep the O.F.C. joint well protected and also to keep extra length of cable which may be required in the event of faults at a later date. The joint chambers are made at site using bricks and mortar or are of pre-cast RCC type.

a) **Construction of brick chamber at site**

For constructing brick chamber, first a pit of size 2m x 2 m x 1.8 m depth is required to be dug. Then, base of the chamber is made using concrete mix of 1:5:10 (1: cement, 5: coarse sand, 10: graded stone aggregate 40mm nominal size) of size of 1.7m x 1.7 m x 0.15 m (thickness). Wall of brick chamber having internal dimensions of 1.2 m x 1.2 m x 1 m (H) should be constructed on this base having wall thickness of 9" using cement mortar mix of 1:5 (1: cement, 5: fine sand). The bricks to be used for this purpose should be of size 9" x 4.5" x 3", best quality available and should have smooth rectangular shape with sharp corners and shall be uniform in colour and emit clear ringing sound when struck. The joint chamber should be so constructed that HDPE/PLB pipe ends remain protruding minimum 5 cms inside the chamber on completion of plastering. The HDPE/PLB pipes should be embedded in wall in such a way so that, the bottom brick should support the pipe and upper brick should be provided in a manner that HDPE/PLB pipe remains free from the weight of the construction. The joint chamber should be plastered on all internal surfaces and top edges with cement mortar of 1:3 (1: cement, 3: coarse sand), 12 mm thick finished with a floating coat of complete cement as per standard. Pre-cast RCC slab with two handles to facilitate easy lifting, of size 0.7 m x 1.4 m and of thickness of 5 cm having one handle for each half in centre and word "OFC" engraved on it are to be used to cover the joint chamber. Two numbers of such slabs are required for one joint chamber. This pre-cast slab should be made of cement concrete mix of 1:2:4 (1: cement, 2: coarse sand, 4: stone aggregate 6 mm nominal size) reinforced with steel wire fabric 75 x 25 mm mesh of weight not less than 7.75 Kg per sq. meter. The joint chamber is filled with clean sand before closing. Lastly, back filling of joint chamber pit with excavated soil is carried out.

b) **Pre cast RCC chamber**

For fixing pre cast RCC chamber, first a pit of size 2 m x 2 m x 1.8 m depth is required to be dug. Pre cast RCC chamber consists of three parts (i) round base plate in two half of 140 cm dia and 5 cm thickness (ii) full round RCC joint chamber with dia of 120 cm and height of 100 cm and thickness of 5 cm (iii) round top cover will be in two halves with dia of 140 cm and thickness of 5 cm having one handle for each half in centre and word 'OFC' engraved on it. (See **figure '5'**). After, fixing the pre cast RCC joint chamber, the joint chamber is filled with clean sand before closing. Lastly, back filling of joint chamber pit with excavated soil is carried out.

6.2.8 **ROUTE/ JOINT INDICATOR**

The route/joint indicators are co-located with each manhole/joint chamber. In addition route indicators are also to be placed where route changes direction like road crossings etc. The route /joint indicator made of pre-cast RCC should have the following dimensions:

Base	-	250 mm x 150 mm
Top	-	200 mm x 75 mm
Height	-	1250 mm

The word 'BSNL OFC' should be engraved on the route/ joint indicators. **(See figure '6' for details)**

The route indicators are painted yellow and the same are placed at 2 ft. away from the centre of the trench towards jungle side. The joint indicators are placed at OFC joints and placed 1 ft. away from wall of the joint chamber facing jungle side and are painted red. The engraved word "BSNL OFC" should be painted in white, on route as well as joint indicators. Numbering of route indicators/joint indicators should also be done in white paint. The numbering scheme for route indicators will be Joint No./Route Indicator No. for that joint. For example, 2/6 marking on a route indicator means 6th route indicator after 2nd joint. Additional joints on account of faults at a later date should be given number of preceding joint with suffix A, B, C, and D. For example sign writing 2A on a joint indicator means, additional joint between joint No. 2 and 3. The numbering of existing route/joint indicator should not be disturbed on account of additional joints. Enamel paints of reputed brand should be used for painting and sign writing of route as well joint indicators.

6.3. **EXACAVATION OF TRENCHES:**

6.3.1 **Trenching Location and Alignment of the Trench:**

In city areas, the trench will normally follow the foot-path of the road except where it may have to come to the edge of the carriage way cutting across road with specific permissions from the concerned authorities maintaining the road (such permissions shall be obtained by the department). Outside the city limits the trench will normally follow the boundary of the roadside land. However, where the road side land is full of burrow pits or forestation or when the cable has to cross culverts/ bridges or streams, the trench may come closer to the road edge or in some cases, over the embankment or shoulder of the Road (permissions for such deviations for cutting the embankment as well as shoulder of the road shall be obtained by the department).

The alignment of the trench will be decided by a responsible departmental official, not below the rank of a Junior Telecom Officer. Once the alignment is marked, no deviation from the alignment is permissible except with the approval of Engineer-in-charge. While marking the alignment only the centre line will be marked and the

Contractor shall set out all other work to ensure that, the excavated trench is as straight as possible. The Contractor shall provide all necessary assistance and labour, at his own cost for marking the alignment.

Contractor shall remove all bushes, undergrowth, stumps, rocks and other obstacles to facilitate marking the centre line without any extra charges. It is to be ensured that minimum amount of bushes and shrubs shall be removed to clear the way and the contractor shall give all, consideration to the preservation of the trees.

The line up of the trench must be such that HDPE Pipe(s) shall be laid in a straight line, both laterally as well as vertically except at locations where it has to necessarily take a bend because of change in the alignment or gradient of the trench, subject to the restrictions mentioned else where.

6.3.2 Line-Up:

The line-up of the trench must be such that HDPE/PLB pipe(s) shall be laid in a straight line except at locations where it has to necessarily take a bend because of change in the alignment or gradient of the trench, subject to the restrictions mentioned elsewhere.

6.3.3 Method of Excavation:

In city limits as well as in built up areas, the contractor shall resort to use of manual labour only to ensure no damage is caused to any underground or surface installations belonging to other public utility services and/or private parties.

However, along the Highways and cross country there shall be no objection to the Contractor resorting to mechanical means of excavation, provided that no underground installations exist in the path of excavation, if any, are damaged.

There shall be no objection to resort to horizontal boring to bore a hole of required size and to push through G.I. Pipe (65 mm/ 40mm dia) through horizontal bore at road crossing or rail crossing or small hillocks etc.

All excavation operations shall include excavation and 'getting out'. 'Getting out' shall include throwing the excavated materials at a distance of at least one meter or half the depth of excavation, whichever is more, clear off the edge of excavation. In all other cases 'getting out' shall include depositing the excavated materials as specified.

In Rocky strata excavation shall be carried out by use of electro mechanical means like breakers or by blasting wherever permissible with express permission from the competent authority. If blasting operations are prohibited or not practicable, excavation in hard rock shall be done by chiseling.

Trenching shall as far as possible be kept ahead of the laying of pipes. Contractor shall exercise due care that the soil from trenching intended to be loose for back filling is not mixed with loose debris. While trenching, the Contractor should not cause damage to any underground installations belonging to other agencies and any damage caused should be made good at his own cost and expense.

Necessary barricades, night lamps, warning board and required watchman shall be provided by the contractor to prevent any accident to pedestrians or vehicles. While carrying out the blasting operations, the contractor shall ensure adequate safety by cautioning the vehicular and other traffic. The contractor shall employ sufficient manpower for this with caution boards, flags, sign writings etc.

The contractor should provide sufficient width at the trench at all such places, where it is likely to cave in due to soil conditions without any extra payment. A minimum

free clearance of 15 cms. Should be maintained above or below any existing underground installation. No extra payment will be made towards this.

In order to prevent damage to HDPE/PLB pipes over a period of time, due to the growth of trees, roots, bushes, etc., the contractor shall cut them when encountered in the path of alignment of trench without any additional charges.

In large burrow pits, excavation may be required to be carried out for more than 165 cms in depth to keep gradient of bed less than 15 degrees with horizontal. If not possible as stated above, alignment of trench shall be changed to avoid burrow pit completely.

6.3.4 Depth and Size of the Trench:

The depth of the trench from top of the surface shall not be less than 165 cms unless otherwise relaxation is granted by competent authority under genuine circumstances. In rocky terrain, the depth of the trench may be restricted to a depth of 100 to 140 cms. However, Engineer-in-charge in exceptional cases due to adverse site conditions encountered, may allow to lay HDPE/PLB pipes at a lesser depth with additional protection. In all cases, the slope of the trench shall not be less than 15 degrees with the horizontal surface. The width of the trench shall normally be 45 cms. at the top & 30 cms. at the bottom. In case, additional pipes (HDPE/GI/RCC Pipes) are to be laid in some stretches, the same shall be accommodated in this normal size trench.

When trenches are excavated in slopes, uneven ground, inclined portion, the lower edge shall be treated, as top surface of land and depth of trench will be measured accordingly. In certain locations, such as uneven ground, hilly areas and all other Places, due to any reason whatsoever it can be ordered to excavate beyond standard depth of 165 cms to keep the bed of the trench as smooth as possible. Near the culverts, both ends of the culverts shall be excavated more than 165 cms. to keep the gradient less than 15 degree with horizontal. For additional depth in excess of 165 cms., additional payment of pro rata basis shall be applicable.

If excavation is not possible to the minimum depth of 165 cms., as detailed above, full facts shall be brought to the notice of the Engineer in charge in writing giving details of location and reason for not being able to excavate that particular portion to the minimum depth. Approval shall be granted by the competent authority in writing under genuine circumstances. The decision of the competent authority shall be final and binding on the contractor.

6.3.5 Dewatering:

The Contractor shall be responsible for all necessary arrangements to remove or pump out water from trench. The Contractor should survey the soil conditions encountered in the section and make his own assessment about dewatering arrangement that may be necessary. No extra payment shall be admissible for this.

6.3.6 Wetting:

Wherever the soil is hard due to dry weather conditions, if watering is to be done for wetting the soil to make it loose, the same shall be done by the contractor. No extra payment shall be admissible for this.

6.3.7 Blasting:

For excavation in hard rock, where blasting operations are considered necessary, the contractor shall obtain approval of the Engineer-in-Charge in writing for resorting to blasting operation.

The contractor shall obtain license from the competent authority for undertaking blasting work as well as for obtaining and storing the explosive as per the Explosive Act, 1884 as amended up to date and the explosive Rules, 1983. The contractor shall

purchase the explosives fuses, detonators, etc. only from a licensed dealer. Transportation and storage of explosive at site shall conform to the aforesaid Explosive Act and Explosive Rules. The contractor shall be responsible for the safe custody and proper accounting of the explosive materials. Fuses and detonators shall be stored separately and away from the explosives. The Engineer-in-Charge or his authorized representative shall have the right to check the contractor's store and account of explosives. The contractor shall provide necessary facilities for this.

The contractor shall be responsible for any damage arising out of accident to workmen, public or property due to storage, transportation and use of explosive during blasting operation.

Blasting operations shall be carried out under the supervision of a responsible authorized agent of the contractor (referred subsequently as agent only), during specified hours as approved in writing by the Engineer-in-Charge. The agent shall be conversant with the rules of blasting.

All procedures and safety precautions for the use of explosives drilling and loading of explosives before and after shot firing and disposal of explosives shall be taken by the contractor as detailed in IS: 4081 safety code for blasting and related drilling operation.

6.3.8 Trenching Near Culverts/ Bridges:

The HDPE/PLB pipes shall be laid in the bed of culvert at the depth not less than 140 cms protected by G.I. pipes and concreting as decided by Engineer- in charge.

Both ends of culverts shall be excavated more than 165 cms in depth to keep the gradient of not less than 15 degree with horizontal. The bed of trench should be as smooth as possible.

While carrying out the work on bridges and culverts, adequate arrangement for cautioning the traffic by way of caution boards during day time and danger lights at night shall be provided.

In case of small bridges and culverts, where there is a likelihood of their subsequent expansion and remodeling, the cable should be laid with some curve on both sides of the culvert or the bridge to make some extra length available for readjustment of the cable at the time of reconstruction of culvert or the bridge.

6.4 LAYING OF PLB H.D.P.E. PIPES:

After the trench is excavated to the specified depth, the bottom of the trench has to be cleared of all stones or pieces of rock and leveled up properly. A layer of soft soil/ or sand (in case the excavated material contains sharp pieces of rock/ stones) of not less than 5 cms is required for leveling the trench to ensure that the cable when laid will follow a straight alignment. Adequate care shall be exercised while laying so that the OF cables are not put to undue tension/pressure after being laid as this may adversely affect the optical characteristics of cables with passage of time.

The contractor shall ensure that trenching and pipe laying activities are continuous, without leaving patches or portions incomplete in between. In case intermediate patches are left, measurement of the completed portions will be taken only after work in such left over patches are also completed in all respects.

Preparatory to aligning the pipe for jointing, each length of the HDPE/PLB pipe shall be thoroughly cleaned to remove all sand, dust or any other debris that may clog, disturb or damage the optical fibre cable when it is pulled at a later stage. The ends of each pipe and inside of each Socket shall be thoroughly cleaned of any dirt or other foreign materials.

After the trench is cleaned the HDPE/PLB pipes/Coil shall be laid in the cleaned trench, jointed with "O" ring type Sockets & 6mm PP rope should be drawn through the HDPE/PLB pipes at the time of laying the pipes to facilitate cable pulling at a later stage. At every manhole approximately at every 200m or at bends or turns the PP rope will be tied to the HDPE end caps used for sealing the HDPE/PLB pipes, to avoid entry of rodents/mud etc.

At the end of each day work, the open ends of the pipes sections shall be tightly closed with end caps to prevent the entry of dirt/mud, water or any foreign matter into HDPE/PLB pipes until the work is resumed.

In City, Town, Urban area falling within Municipal/Corporation limits, the HDPE/ LB pipes shall be laid with protection using RCC/G.I. Pipes/ Concreting reinforced with weld mesh. Moreover, in cross country routes, if depth is less than 1.2 meters, protection by using RCC/G.I. Pipe/ Concreting reinforce with weld mesh shall be provided. Engineer-in-Charges shall decide about such stretches and type of protection to be provided in view of the site requirements. Normally 100 mm RCC Pipes shall be used for protecting HDPE/PLB pipe but if more than one HDPE/PLB pipe is to be laid and protected, RCC Pipe of suitable size to accommodate the required number of HDPE Pipes shall be used.

The HDPE/PLB pipes shall be laid in RCC Full Round spun Pipes/GI Pipes as required at road crossings. The RCC pipes/GI pipes shall extend at least 3 meters on either side of the road at road crossings. At road crossings, extra GI/HDPE/PLB pipes may be laid as per the direction of the Engineer-in charge. On Rail bridges and crossings, the HDPE/PLB pipes shall be encased in suitable cast iron as prescribed by the Railway Authorities.

Wherever RCC pipes are used for protection, the gaps between the RCC collars and the RCC pipes shall be sealed using cement mortar 1:3 (1:53 grade cement of reputed brand, 3: fine sand without impurities) to bar entry of rodents. Every third collar of RCC pipes (normally of 2 meters length) and also both ends of RCC Pipes will be embedded in a concrete block of size 40 cms (L)x 40 cms (W) x 25 cms (H) of 1:2:4 cement concrete mix (1:53 grade cement of reputed brand, 2: coarse sand, 3: stone aggregate of nominal size of 20 mm) so that the alignment of RCC pipes remain firm and intact and to avoid entry of rodents.

Wherever GI pipes are used, special care should be taken to ensure that G.I. Pipes are coupled properly with the sockets so as to avoid damage to HDPE/PLB pipe and eventually the OF Cable in the event of pressure coming on the joint and G.I. Pipe joint giving its way. Rubber bushes shall be used at either ends of the GI pipes to protect HDPE/PLB pipe. Both the ends of G.I. Pipe will be embedded in a concrete block of size 40 cms (L)x 40 cms ((W) x 25 cms (H) of 1:2:4 cement concrete mix (1:53 grade cement of reputed brand, 2: coarse sand,

3: stone aggregate of nominal size of 20 mm) so that the alignment of G.I. Pipes remain firm and intact and to avoid entry of rodents.

In case of protection by concreting at site, the nominal dimension of concreting shall be 250 mm x 250 mm section. Cement Concrete Mixture used shall be of 1:2:4 composition i.e. 1:53 grade Cement of a reputed company , 2: Coarse Sand, 4: Graded Coarse Stone aggregate of 20 mm nominal size, reinforced with MS weld mesh. As the RCC is cast at site, it is imperative to ensure that special care is taken to see that proper curing arrangements are made with adequate supply of water. The contractor shall invariably use mechanical mixer at site for providing RCC protection, to ensure consistency of the mix.

For carrying out concreting work in trenches, yellow PVC sheets of width not less than 1.0 M and of weight not less than 1 kg. Per 8 sq. meters shall be spread and nailed on sides of the trench to form trapezoidal section for concreting in the cleaned trench, to avoid seepage of water into the soil. A bed of cement concrete mixture of appropriate

width and 75 mm thickness shall be laid on the PVC sheet, before laying HDPE pipes. The HDPE/PLB pipes shall then be laid above this bed of concrete. After laying the HDPE/PLB pipes, MS weld mesh is wrapped around and tied and concrete mix is poured to form the cross sectional dimensions as instructed by the Engineer-in-charge. The strength of RCC is dependent on proper curing, therefore, it is imperative that water content of RCC mix does not drain out into the surrounding soil. Portions where cement concreting has been carried out shall be cured with sufficient amount of water for reasonable time to harden the surface. After curing, refilling of the balance depth of the trench has to be carried out with excavated soil.

The HDPE/PLB pipes/RCC/GI Pipes shall be laid only in trenches accepted by Engineer-in-Charge or his representative. The Contractor shall exercise due care to ensure that the HDPE/PLB pipes are not subjected to any damage or strain. Water present in the trench at the time of laying the HDPE/PLB pipes shall be pumped out by the contractor before laying the pipes in the trench to ensure that no mud or water gets into the pipes, thus choking it.

In case of nallahs, which are dry for nine months in a year, the HDPE/PLB pipes shall be laid inside the RCC Pipes/ or GI Pipes and concrete laid at a minimum depth of 165 cms., as instructed by the Engineer-in-charge. The mechanical protection shall extend at least 5 meters beyond the bed of nallah on either side.

notwithstanding anything contained in clauses referred above, the Engineer-in-charge may order, based on special site requirements, that the HDPE Pipes may be encased in reinforced cement concrete, as detailed, *ibid*.

While laying the pipes, a gap of 2 M is kept at convenient locations approx. 200 m apart and at the bends and turns, which will be used as manholes during OF cable pulling. Ends of the HDPE/PLB pipes at the manholes shall be sealed using end caps after tying the PP rope to the end caps to avoid choking of the pipes. In a similar manner, manholes shall be kept while approaching bridges, road crossings etc., as instructed by the Engineer-in-charge. The location of the manholes will be decided by the Engineer-in-charge.

6.4.1 Laying Protection Pipes on Bridges and Culverts:

In case trenching and pipe laying is not possible in the beds of the culverts, the pipes shall be laid over the culverts/bridges after getting due permission from the competent authority. Of late the bridge construction authorities are providing ducts below the footpaths on the bridges for various services. The telecom officers need to maintain good liaison with the concerned authority to get one side of the duct allotted for Telecom Cables. In such ducts, G.I. Pipes can be coupled and laid for pulling the cables. It would be pertinent to mention here that close liaison with bridge construction authorities would be of immense advantage in ensuring provision of ducts on one or both the sides of the bridges as per future requirements. However, for laying cables on existing bridges, where duct arrangement does not exist, one of the following methods may be adopted.

Normally in the Bridges/ Culverts, where there are no ducts and where the cushion on the top of the Arch is 50 cm to 100 cm or more, G.I. Pipe (Carrying HDPE/PLB pipe and cable) may be buried on the top of the Arch adjoining the parapet wall, by digging close to the wheel guards. Every precaution shall be taken to see that no damage occurs to the arch of the culvert. After burying the GI pipe, the excavated surface on the arch shall be restored.

Where the thickness of the Arch is less than 50 cms, the pipe must be buried under the wheel guard masonry and the wheel guard rebuilt.

If neither of the two methods is possible, the G.I. Pipes/GI Troughs must be clamped outside the parapet wall with the clamps supplied by the department. If necessary, the pipes may be taken through the parapet wall at the ends where the wall diverges away from the road.

In case where the methods explained in clauses referred above are not possible, the G.I. Pipe/GI Troughs can be fixed on the top of the road kerb close to the inside face of the parapet wall by means of clamps supplied, using raw plugs and wood screws or small diameter bolts, without damaging the concrete and limiting the external diameter of the bolts to 7.5 mm. The permission for carrying out this work will be obtained from the Road Authorities by the department.

Methods cited in above clauses should be carried out under close supervision of Road authorities.

The surface to be concreted should be thoroughly cleaned and leveled before concreting. At both ends of the Bridges/Culverts, where the GI Pipes /GI Troughs slope down and get buried, the concreting should be extended to ensure that no portion of the GI Pipes/GI Troughs is exposed as ordered by the Engineer- in- charge to protect the pipe/Trough from any possible damage externally caused.

Where white wash/ colour wash is existing on the Bridges/ Culverts, the same should also be carried out on the concreted portion to ensure uniformity.

6.5 Back Filling and Dressing of the Trench:

The earth used for filling shall be free from all roots. Grass, shrubs, vegetation, trees, saplings and rubbish. Provided that the HDPE/PLB pipes have been properly laid in the trench at the specified depth, the back filling operation shall follow as closely as practicable. The back filling operation shall be performed in such a manner so as to provide firm support under and above the pipes and to avoid bend or deformation of the HDPE/PLB pipes when the pipes get loaded with the back filled earth.

At locations where the back filled materials contains stones/sharp objects which may cause injury to the HDPE/PLB pipes and where the excavated or rock fragments are intended to refill the trench in whole or in part, the trench should be initially filled, with a layer of ordinary solid or de-rocked loose earth of not less than 10 cms above the pipes. Back filling on public, private roads, railway crossings, footpaths in city areas shall be performed immediately after laying the HDPE pipes. Back filling at such locations shall be thoroughly rammed, so as to ensure original condition and made safe for traffic. All excess soil/ material left out on road/ footpath/railway crossing shall be removed by contractor.

However, along the high way and cross-country, the dug up material left out should be kept as heap above the trench while refilling.

In city limits, no part of the trench should be kept open for more than 50 meter length at any time and in all places where excavation has been done, no part of the trench should be kept open over night to prevent any mishap or accident in darkness.

6.6 CABLE PULLING AND JOINING/ SPLICING :

6.6.1 CABLE PULLING :

Manholes marked during HDPE/PLB pipe laying of approx. size of 3m length x 1.0 m. width x 1.65 m. Depth shall be excavated for pulling the cables. There may be situations where additional manholes are required to be excavated, for some reasons, to facilitate smooth pulling of cable. Excavation of additional manholes will be carried out, without any extra cost. De-watering of the manholes, if required, will be carried out without any

extra costs. De-watering/De-gasification of the ducts, if required, will be carried out without any extra costs.

The existing 6mm PP rope shall be replaced by with PP rope of 8 mm dia between the two consecutive manholes. This is to ensure that the HDPE/PLB pipes are cleaned for pulling the cable without exerting undue tension on the OF cable. While cleaning, excessive pressure should not be put which may result in breaking of P.P rope and thus require opening of additional manholes? However, in case the cleaning rope gets stuck up during pulling, the location of clogging of HDPE/PLB pipe should be measured and located accurately. The trench at that location should be opened and the HDPE/PLB pipe should be cleaned properly or if not possible it should be changed by a clean new HDPE Pipe to facilitate easy cable pulling at a later stage without any breakage. If clogging of HDPE/PLB pipe is in the location where the pipes are protected either by RCC Pipe or by concreting and the protection is broken for cleaning/changing the HDPE/PLB pipe, the protection thus removed should be brought back to normal by the contractor without any extra cost. However, HDPE Pipes, RCC Pipes required for this purpose will be supplied by the Department.

The Optical fibre cables are available in drums in lengths of approx. 2 kms. The cables shall be manually pulled through already laid HDPE/PLB pipes by using the 8 mm PP rope. This work is to be carried out under the strict supervision of site in-charge. At a time, maximum three persons at every manhole should be deployed to pull the cable as more tension to cable may lead to breaking of fibers. Cost of such damages will be recovered form the contractor.

After pulling of the drum is completed, both ends of the HDPE/PLB pipe in each manhole should be sealed by hard rodent resistant rubber bush, to avoid entry of rodents/mud into HDPE/PLB pipes.

The Manholes are prepared by providing 65mm split HDPE/PLB pipe of 2.5 to 3m length and closing the split HDPE/PLB pipes by providing necessary clamps/ adhesive tape as per the directions of Engineer-in- charge. Afterwards, the split/cut HDPE/PLB pipe are covered with 100 mm split RCC pipe of 2m length and sealing the ends of RCC pipe with lean cement solution for protecting bare cable in the manhole . After fixing of HDPE/RCC Split Pipes necessary back filling/reinstatement and dressing of manholes should be carried out as referred under trenching. The location of the pulling manhole should be recorded for preparation of documentation.

6.6.2 Jointing/ Splicing :

The OFC cable drums are usually of 2 kms in length hence optical fibre joints will be approx. at every 2 Kms. The 6/12/24 fibers are to be spliced at every 2 kms. & at both ends (Terminations) in the equipment room as directed by the Engineer-in-charge. The Infrastructure required for cable splicing is

- Splicing machine
- Air Conditioned Van
- OTDR
- Optical talk set
- Tool kit etc.

Will be arranged by the bidder at his own cost and also any additional accessories. E.g. engine etc. required at site for splicing will also be arranged by the bidder at his own cost.

The optical fibre cable thus jointed end-to-end will be tested by an officer of A/T unit for splice losses and transmission parameters as specified by TCHQ and prevalent at that time. The OF cable should meet all the parameters, specified and no relaxation will be granted.

It should also be ensured that during jointing no fibers are interchanged or broken. The number of joints should not be more than 10 % of the theoretical value calculated by the department.

6.7 Construction of Jointing Chamber :

The joint chambers are provided at every joint to keep the O.F.C. joint well protected and also to keep extra length of cable, which may be, required to attend the faults at a later date. Jointing chambers are to be prepared normally at a distance of every 2 kms. Actual location of jointing chamber depends on length of cable drum and appropriateness of location for carrying out jointing work. The location is finalized by Engineer-in-charge. The jointing chambers are constructed either of brick masonry work at site & pre cast RCC slabs for covers or by way of fixing pre-cast RCC chambers and covers as per the instructions from Engineer-in-charge.

6.7.1 Construction of brick chamber at site:

For constructing brick chamber, first a pit of size 2 m x 2 m x 1.8m depth is required to be dug. Then, base of the chamber is made using concrete mix of 1:5:10 (1: cement, 5: coarse sand, 10: graded stone aggregate 40 mm nominal size) of size of 1.7 m x 1.7 m x 0.15 m (thickness). Walls of brick chamber having internal dimensions of 1.2 m x 1.2 m x 1 m (H) should be constructed on this base having wall thickness of 9" using cement mortar mix of 1:5 (1: cement, 5: fine

sand). The bricks to be used for this purpose should be of size 9" x 4.5" x 3", best quality available and should have smooth rectangular shape with sharp corners and shall be uniform in colour and emit clear ringing sound when struck. The joint chamber should be so constructed that HDPE pipe ends remain protruding minimum 5 cms inside the chamber on completion of plastering. The HDPE/PLB pipes should be embedded in wall in such a way so that, the bottom brick should support the pipe and upper brick should be provided in a manner that HDPE pipe remains free from the weight of the construction. The joint chamber should be plastered on all internal surfaces and top edges with cement mortar of 1:3 (1: cement, 3 coarse sand) 12 mm thick finished with a floating coat of complete cement as per standard. Pre-cast RCC slab with two handles to facilitate easy lifting, of size 0.7 m x 1.4 m and of thickness of 5 cm having one handle for each half in centre and word 'OFC' engraved on it are to be used to cover the joint chamber. Two numbers of such slabs are required for one joint chamber. This

pre-cast, slab should be made of cement concrete mix of 1:2:4 (1: cement, 2: coarse sand, 4 stone aggregate 6 mm nominal size) reinforced with steel wire fabric 75 x 25 mm of weight not less than 7.75 Kg per sq. meter The joint chamber is filled with clean sand before closing. Lastly, back filling of joint chamber pit with excavated soil should be carried out up to normal ground level and compacted.

6.7.2 Pre cast RCC chamber :

For fixing pre cast RCC chamber, first a pit of size 2 m x 2m x 1.8 m depth is required to be dug. Pre cast RCC chamber consists of three parts (i) round base plate in two half of 140 cm dia and 5 cm thickness (ii) full round RCC joint chamber with dia of 120 cm and height of 100 cm and thickness of 5 cm (iii) round top cover will be in two halves with dia of 140 cm and thickness of 5 cm having one handle for each half in centre and word 'OFC' engraved on it. (See figure '4') Pre cast RCC chamber (which is coming in part) should be placed in the pit and parts should be fixed by applying cement mortar. The pre cast RCC chamber will be supplied by the department. After, fixing the pre cast RCC joint chamber, the joint chamber is filled with clean sand before closing. Lastly, back filling of joint chamber pit with excavated soil should be carried out up to normal ground level and compacted.

The work of cable pulling includes the work of cable pulling up to exchange termination point and has to be carried out as per the directions of Engineer-in-charge.

6.8 Fixing of Route Indicators/ Joint Indicators :

Pits shall be dug 1 M. towards jungle side at every manhole and jointing chamber for fixing of Route/Joint Indicator. In addition, Route Indicators are also required to be placed where O.F. Cable changes directions like road crossing etc.

The pits for fixing the indicator shall be dug for a size of 60 cms. x 60 cms. and 75 cms. (depth). The indicator shall be secured in upright position by ramming with stone and murrum up to a depth of 60 cms. and concreting in the ratio of 1:2:4 (1: cement, 2: coarse sand, 4 stone aggregate 20 mm nominal size) for the remaining portion of 15 cms. Necessary curing shall be carried out for the concreted structure with sufficient amount of water for reasonable time to harden the structure.

The route and joint indicator shall be painted with primer before painting with oil paint. The material used should bear ISI mark. The size of each written letter should be at least 3.5 cms. The colors of painting and sign writing is as under:

- a) For Joint Indicator Red.
- b) For Route Indicator Yellow.
- c) For Letters White.

The numbering scheme for route indicators will be Joint No./Route Indicators No. for that joint. For example 2/6 indicator means 6th route indicator after 2nd joint. Additional joints on account of faults at a later date should be given number of preceding joint with suffix A, B, C and D. For example sign writing 2A on a joint indicator means, additional joint between Joint No. 2 and 3. The numbering existing route/ joint indicator should not be disturbed on account of additional joints.

6.9 Documentation :

The documentation, consisting of the following shall be prepared exchange to exchange for Intra SSA OFC links and for each section in case of inter SSA/National Long distance routes.

- a) **L-14 Diagrams** – General: This diagram shall consist of Cable Route Details on Geographical Map drawn to scale with prominent land marks and alignment of cable with reference to road. This shall be prepared on A-3 sheets of 80 GSM. There should be location of joint and important landmark.
- b) **Route Index Diagrams** –Profile: These diagrams will contain:
 - Make and size of the cable.
 - Offset of cable from centre of the road at every 10 meters;
 - Depth profile of Cable at every 10 meter;
 - Details of protection with type of protection depicted on it;
 - Location of culvert and bridges with their lengths and scheme of laying of HDPE/PLB pipe thereon.
 - Important landmarks to facilitated locating the cable in future;
 - Location of Joints and pulling manholes.These diagrams shall be prepared on **A-4 sheets** of 80 GSM. On one sheet profile of maximum 400 meters shall be given to ensure clarity.

SAFETY PRECAUTIONS:

6.10.1 Safety Precautions when excavating or working in excavations close to electric cables

The Engineer- in-charge of the work should get full information from Electricity undertaking regarding any electric cables, which are known or suspected to exist near the proposed excavation and unless this is done, excavation should not be carried out in the section concerned. The electricity undertaking should be asked to send a representative and work should be preceded with close consultation with them.

Only wooden handled hand tools should be used until the electric cables have been completely exposed. Power Cables, not laid in conduits, are usually protected from above by a cover slab of concrete, brick or stone. They may or may not be protected on the sides. It is safer, therefore, always to drive the point of the pickaxe downwards then uncovering a cable, so that there is less chance of missing such warning slabs. No workman should be permitted to work alone where there are electric cables involved. At least one more man should be working near by so that help can be given quickly in case of an accident. If disconnection of power could be arranged in that section it will be better. No electric cables shall be moved or altered without the consent of the Electric

Authority and they should be contacted to do the needful. If an electric cable is damaged even slightly, it should be reported to the Electric Authority and any warning bricks disturbed during excavation should be replaced while back filling the trench. Before driving a spike into the ground, the presence of other underground properties should be checked. Information on plans regarding the location of power cables need not to be assumed as wholly accurate. Full precautions should be taken in the vicinity until the power cable is uncovered. All electric cables should be regarded as being live and consequently dangerous. Any power is generally dangerous, even low voltage proving fatal in several cases.

6.10.1.1 Electric shock-Action and treatment :

Free the victim from the contact as quickly as possible. He should be jerked away from the live conductors by dry timber, dry rope or dry clothing. Care should be taken not to touch with bare hands as his body may be energized while in contact. Artificial respiration should begin immediately to restore breathing even if life appears to be extinct. Every moment of delay is serious, so, in the meanwhile, a doctor should be called for.

6.10.2 Safety Precautions while working in Public Street and along railway lines:

Where a road or footpath is to be opened up in the course of work, special care should be taken to see that proper protection is provided to prevent any accidents from occurring. Excavation work should be done in such a manner that it will not unduly cause inconvenience to pedestrians or occupants of buildings or obstruct road traffic. Suitable bridges over open trenches should be so planned that these are required for the minimum possible time. Where bridges are constructed to accommodate vehicular traffic and is done near or on railway property, it should be with the full consent and knowledge of the competent railway authorities.

6.10.2.1 Danger from falling material :

Care should be taken to see that apparatus, tools or other excavating implements or excavated materials are not left in a dangerous or insecure position so as to fall or be knocked into the trench thereby injuring any workman who may be working inside the trench.

6.10.2.2 Care when working in Excavations :

Jumping into a trench is dangerous. If it is deep, workmen should be encouraged to lower themselves. Workers should work at safe distance so as to avoid striking each other accidentally with tools. If the walls of the trench contain glass bits, corroded wire or sharp objects they should be removed carefully. If an obstruction is encountered, it should be carefully uncovered and protected if necessary. If an obstruction is encountered, it should be carefully uncovered and protected if necessary. Care must be taken to see that excavated

material is not left in such a position that it is likely to cause any accident or obstruction to a roadway or waterway. If possible the excavated material should be put between the workmen and the traffic without encroaching too much on the road.

6.10.2.3 Danger of cave in :

When working in deep trenches in loose soil, timbering up/shoring the sides will prevent soil subsidence. The excavated material should be kept at sufficient distance from the edge of the trench or pit. Vehicles or heavy equipment must not be permitted to approach too close to the excavation. When making tunneled opening, it should be ensured that the soil is compact enough to prevent cave in even under adverse conditions of traffic. Extra care should be taken while excavating near the foundations of buildings or retaining walls. In such cases, excavation should be done gradually and as far as possible in the presence of the owners of the property.

6.10.2.4 Protection of Excavations:

Excavations in populated areas, which are not likely to be filled up on the same day should be protected by barriers or other effective means of preventing accidents and the location of all such openings must in any event be indicated by red flags or other suitable warning signs. During the hours from dusk to dawn, adequate number of red warning lamps should be displayed. Supervisory officers should ensure that all excavations are adequately protected in this manner as serious risk and responsibility is involved. Notwithstanding adoption of the above mentioned precautions, works involving excavations should be so arranged as to keep the extent of opened ground and the time to open it to a minimum.

6.10.2.5 Precautions while working on roads:

The period between half an hour after sun-set and half an hour before sunrise, and any period of fog or abnormal darkness may also be considered as night for the purpose of these instructions, for the purpose of providing the warning signs. Excavation liable to cause danger to vehicles or the public must at all times be protected with fencing of rope tied to strong uprights or bamboo poles at a suitable height or by some other effective means. Any such temporary erection which is likely to cause obstructions and which is not readily visible should be marked by posts carrying red flags or boards with a red background by day and by continuously lighted lamps at night.

The flags and the lamps should be placed in conspicuous positions so as to indicate the pedestrians and drivers of vehicles the full expanse i.e. both width and length of the obstruction. The distance between lamps or between floors should not generally exceed 1.25 m along the width and 6m along length of the obstruction in non congested areas, but 4 meters along the length in

Congested areas. If the excavation is extensive, sufficient notice to give adequate warning of the danger should be displayed conspicuously not less than 1.25 m above the ground and close to the excavation. Where any excavation is not clearly visible for a distance of 25m to traffic approaching from any direction or any part of the carriage way of the road in which the excavation exists, a warning notice should be placed on the kerb or edge of all such roads from which the excavation or as near the distance as is practicable but not less than 10 m from the junction of an entering or intersecting

road in which the excavation exists. All warnings, in these should have a red background and should be clearly visible and legible. All warning lamps should exhibit a red light, but white lights may be used in addition to facilitate working at night. Wherever required a passage for pedestrians with footbridge should be provided. At excavations, cable drums, tools and all materials likely to offer obstructions should be properly folded round and protected. This applies to jointer's tents as well. Leads, hoses etc. stretched and across the carriageway should be guarded adequately for their own protection and also that of the public.

6.10.2.6 Traffic Control :

The police authorities are normally responsible for the control of traffic and may require the setting up of traffic controls to reduce the inconvenience occasioned by establishment of a single line of traffic due to restriction in road width or any other form of obstruction caused by the work. As far as possible, such arrangements should be settled in advance. If there are any specific regulations imposed by the local authorities, these should be followed.

6.10.2.7 Work along Railway Lines ;

Normally all works at Railway crossing is to be done under supervision of the railway authorities concerned, but it is to be borne in mind that use of white, red or green flags by the Departmental staff is positively forbidden to be used when working along a railway line as this practice may cause an accident through engine drivers mistaking them for railway signals. When working along a double line of railway, the men should be warned to keep a sharp look on both the "UP" and "DOWN" lines to avoid the possibility of any accident when trains pass or happen to cross one another near the work spot.

6.10.3 Procedure and Safety Precautions for use of explosives during blasting for trenching:

In areas where the cable trench cannot be done manually on account of boulders and rocks, it is necessary to blast the rocks by using suitable explosives. The quality of explosive to be used depends on the nature of the rocks and the kind of boulders. A few types of explosive fuses and detonators normally used for making trenches for cable works are detailed below:

- a) Gun powder
- b) Nitrate Mixture
- c) Gilatine
- d) Safety fuse
- e) Electric Detonator
- f) Ordinary Detonator

The permission shall be taken by contractor from local authority for use and at his risk and responsibility.

6.10.3.1 Procedure:

A detailed survey of the route is to be done to assess the length of the section where trenching is to be done with the help of blasting. A route diagram of the rocky section may be prepared indicating the length of the route where the explosives are to be used. For the purpose of obtaining license, a longer length of route should be given in the application as in many cases, after digging, rocks appear which was not initially anticipated.

Next a license will have to be obtained for use and storing of explosive in that section. If the area falls under a police commissioner, the authority for granting such license is the police commissioner of the concerned area. When the route

does not fall in the jurisdiction of a police commissioner, the authority for issuing license is the District Magistrate.

The concerned authority should be applied in prescribed form with a route map. The concerned authority will make an enquiry and issue license for using/storing explosives for cables trenching work. Such license will be valid for 15 days only. The license should be got renewed if the blasting operation needs to be extended. Once the license is granted, it is the responsibility of the holders of the license for the proper use of explosives, its transportation and storing.

6.10.3.2 Method of using :

The safest explosive is the Gilatine and electric detonator. Gilatine is in the form of a stick. Electric detonator is a type of fuse used for firing the

explosive electrically. Holes are made at suitable intervals on rocky terrain or boulders either by air compressor or by manual chipping. The depth of the holes should be 2 to 3 ft. Fill up the holes with small quantity of sand for about 6". First the electric detonator is to be inserted into the Gilatine and the Gilatine is to be inserted into the holes keeping the + ve and- ve wirings of electric detonators outside the holes. Again refill the holes with sand. These +ve and-ve insulated wires of detonator are then extended and finally connected to an EXPLODER kept at a distance of not less than 100 m.

Now the explosive is ready for blasting. But, before connecting wires to exploder for blasting, all necessary precautions for stopping the traffic, use of red flags, exchange of caution signals, etc. , should be completed and only then Exploder should be connected and operated.

6.10.3.3 Operation of exploder (IDL schaffler type 350 type exploder) :

The type 350 blasting machine consists of a bearing block with blasting machine system and the explosion proof light- alloy injection molded housing. The exploder is held with the left hand. The twist handle is applied to the drive pin, clapped with the right hand turned in the clock wise direction in continuous measurements at the highest speed from the initial position until it reached to a stop. At this stage an indication lamp will glow. When the indication lamp glows, "press button switch" should be pressed. This will extend the electric current to detonator and Gilatine will be detonated. The rock will be blasted out of the trench. Number of holes can be blasted in a single stroke by connecting all such detonators in series connection and finally to the exploder. After blasting, again mazdoors are engaged on the work to clear the debris. If the result of the first blasting is not satisfactory, it should be repeated again on the same place.

6.10.3.3.1 Warning :

There may be two reasons for unsatisfactory results of the blasting :

- a) Misfire of Gilatine due to leakage of current from detonator.
- b) Over loading because of overburdens.

Never pull the broken wire pieces from the holes in such cases. Attempt should not be made to re blast the misfired Gilatine. The safest way is to make a fresh hole by its side and put fresh Gilatine in that hole and blast it.

6.10.3.4 Precautions :

The abstract of Explosives Rules 1983 which are relevant to our work is given below:

6.10.3.5.1 Restriction of delivery and dispatch of explosives:

No person shall deliver or dispatch any explosives to anyone other than a person who.

a) is the holder of a license to possess the explosives or the agent of a holder of such a license duly authorized by him in writing on his behalf.

OR

b) is entitled under these rules to possess the explosives without a license.

The explosives so delivered or dispatched shall in no case exceed the quantity, which the person to whom they are delivered or dispatched is authorized to possess with or without a license under these rules. No person shall receive explosives from any person other than the holder of a license granted under these rules. No person shall receive from or transfer explosives to any person for a temporary storage or safe custody in a licensed premise unless prior approval is obtained from the Chief Controller.

A person holding license for possession of explosives granted under these rules shall store the explosives only in premises specified in the license.

6.10.3.5.2 Protection from Lightning During Storing :

Every magazine shall have attached there to one or more efficient lightning conductors designed and erected in accordance with the specification laid down in Indian Standard Specifications No. 2309 as amended from time to time. The connections to various parts of earth resistance of the lightning conductor terminal on the building to the earth shall be tested at least once in every year by a qualified electrical engineer or any other competent person holding a certificate of competency in this behalf from the State Electricity Department. A certificate showing the results of such tests and the date of the last test shall be hung up in conspicuous place in the building.

6.10.3.5.3 Precautions during thunder-storm :

When a thunder- storm appears to be imminent in the vicinity of a magazine or store house every person engaged in or a round such magazine and store house shall be withdrawn to a safe distance from such magazine or store house and the magazine and store house shall be kept closed and locked until the thunder storm has ceased or the threat of it has passed.

6.10.3.5.4 Maintenance of records:

Every person holding a license granted under these rules for possession, sale or use of explosives shall maintain records in the prescribed form and shall produce such record on demand to an Inspection Officer.

6.10.3.5.5 Explosives not to be kept in damaged boxes:

The licensee of every magazine or store house shall ensure that, the explosives are always kept in their original outer package. In case, the outer package gets damaged so that the explosive contained therein cannot be stored or transported, such explosives shall be repacked only after the same are examined by controller of explosives.

6.10.3.5.6 Storage of explosives in excess of the licensed quantity:

The quantity of any kind of explosives kept in any licensed magazine or store house shall not exceed the quantity entered in the license against such kind of explosives. No explosives in excess of the licensed quantity shall be stored in the

magazine or store house unless a permit in this behalf is obtained from the licensing authority by a letter or telegram.

6.10.3.5.7 Precautions to be observed at Site:

The electric power at the blasting site shall be discontinued as far as practicable before charging the explosives. No work other than that associated with the charging operations shall be carried out within 10 meters of the holes unless otherwise specified to the contrary by the licensing authority. When charging is completed, any surplus explosive detonators and fuses shall be removed from the vicinity of the hole and stored at a distance which should prevent accidental detonation in the event of a charge detonating prematurely in any hole. The holes which have been charged with explosive shall not be left unattended till the blasting is completed. Care shall be taken to ensure that fuse or wires connected to the detonation are not damaged during the placing of stemming materials and tamping.

6.10.3.5.8 Suitable warning procedure to be maintained:

The licensee or a person appointed by the licensee to be in charge of the use of explosives at the site shall lay down a clear warning procedure consisting of warning signs and suitable signals and all persons employed in the area shall be made fully conversant with such signs and signals.

6.10.3.5.9 Precautions to be observed while firing:

The end of the safety fuse (if used in place of a detonator should be freshly cut before being lighted. The exploders shall be regularly tested and maintained in a fit condition for use in firing. An exploder shall not be used for firing a circuit above its rated capacity. The electric circuits shall be tested for continuity before firing. All persons other than the shot-firer and his assistant, if any, shall be withdrawn from the site before testing the continuity.

For the purpose of jointing, the ends of all wires and cables should have the insulation removed for a maximum length of 5 cms. and should, then be made clear and bright for a minimum length of 2.5 cms. and the ends to be joined should be twisted together so as to have a positive metal contact. Then these should be taped with insulation to avoid leakage when in contact with earth.

In case of blasting with dynamite or any other high explosive, the position of all the bore holes to be drilled shall be marked in circles with white paint. These shall be inspected by the Contractor's agent. Bore holes shall be of a size that the cartridge can easily pass down. After the drilling operation, the agent shall inspect the holes to ensure that drilling has been done only at the marked locations and no extra hole has been drilled. The agent shall then prepare the necessary charge separately for each bore hole. The bore holes shall be thoroughly cleaned before a cartridge is inserted. Only cylindrical wooden tamping rods shall be used for tamping. Metal rods or rods having pointed end shall never be used for tamping.

One cartridge shall be placed in the bore hole and gently pressed but not rammed down. Other cartridges shall then be added as may be required to make up the necessary charge for the bore hole. The top most cartridge shall be connected to the detonator which shall in turn be connected to the safety fuses of required length. All fuses shall be cut to the length required before being inserted into the holes. Joints in fuses shall be avoided. Where joints are

unavoidable, a semi-circular niche shall be cut in one piece inserted into the niche. The two pieces shall then be wrapped together with string. All joints exposed to dampness shall be wrapped with rubber tape. The maximum of eight bore holes shall be loaded and fired at one occasion. The charges shall be fired successively and not simultaneously. Immediately before firing, warning shall be given and the agent shall see that all persons have retired to a place of safety. The fuses of the charged holes shall be ignited in the presence of the agent, who shall see that all the fuses are properly ignited.

Careful count shall be kept by the agent and other of each blast as it explodes. In case all the charged bore holes have exploded, the agent shall inspect the site soon after the blast but in case of misfire the agent shall inspect the site after half an hour and mark red crosses (X) over the holes which have not exploded. During this interval of half an hour, nobody shall approach the misfired holes. No driller shall work near such bore until either of the following operations has been done by the agent for the misfired boreholes.

- a) The contractor's agent shall very carefully (when the tamping is damp clay) extract the tamping with a wooden scraper and withdraw the primer and detonator.
- b) The holes shall be cleaned for 30 cm of tamping and its direction ascertained by placing a stick in the hole. Another hole shall then be drilled 15 cm away and parallel to it. This hole shall be charged and fired. The misfired holes shall also explode along with the new one.

Before leaving the site of work, the agent of one shift shall inform the agent relieving him for the next shift, of any case of misfire and each such location shall be jointly inspected and the action to be taken in the matter shall be explained to the relieving agent.

The Engineer-in-charge shall also be informed by the agent of all cases of misfire, their cause and steps taken in that connection.

6.10.3.6 General Precautions:

For the safety of persons red flags shall be prominently displayed around the area where blasting operations are to be carried out. All the workers at site, except those who actually ignite the fuse, shall withdraw to a safe distance of at least 200 meters from the blasting site. Audio warning by blowing whistle shall be given before igniting the fuse.

Blasting work shall be done under careful supervision and trained personnel shall be employed. Blasting shall not be done within 200 meters of an existing structure, unless specifically permitted by the Engineer-in-Charge in writing.

6.10.3.7 Precautions against misfire:

The safety fuse shall be cut in an oblique direction with a knife. All saw dust shall be cleared from inside of the detonator. This can be done by blowing down the detonator and tapping the open end. No tools shall be inserted into the detonator for this purpose.

If there is water present or if the borehole is damp, the junction of the fuse and detonator shall be made water tight by means of tough grease or any other suitable material. The detonator shall be inserted into the cartridge so that about one-third of the copper tube is left exposed outside the

For coupling HDPE/PLB pipes/ coils, HDPE sockets as per IS 4984-1995 ('()' ring type) made of High Density Polyethylene 50') or equivalent injection trade material should be used. The HDPE sockets should be black in colour and should be fitted with hand rubber rings at both and and should confirm to GR No. G/CDS-05/01 dated December, 1994 and revised up to date. 5mm x 5 mm projections inside at the centre of the socket should be provided to pr event the pipes from passing through. It should weigh 150 gm (with a tolerance of 1/- 5%) and should be able to withstand the pressure of 10 kg per sq. cms. Without any damage/ deterioration in performance. (See figure '1' for details)

Fig.2

HDPE END CAPS

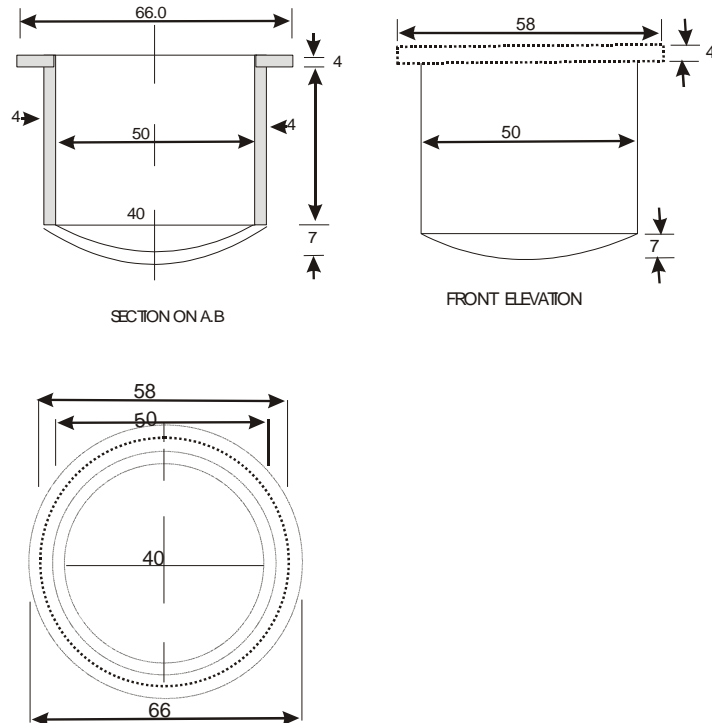

For pulling the cable through the pipes, it is necessary to have suitable manholes at every 200 M length and at suitable bends and corners. The pipes are land for 200 M or less at a time for the distance between two manholes. The ends of the HDPE/PLB pipes/ coils are closed with HDPE End Caps. The End Caps used should be suitable for closing 50 mm outer diameter class size HDPE/PLB pipes. The end cap should be manufactured from High Density Polyethylene, should withstand internal pressure of 10 kg per sq. cms., should be black in colour, and should have a weight of 100 gms. (with a tolerance of 1/-5%) and should conform to G/CDS- 05/01 dated December, 1994 and revised upto date. (See figure '2' for details)

Fig. 3
Rubber Bush/ Cork:

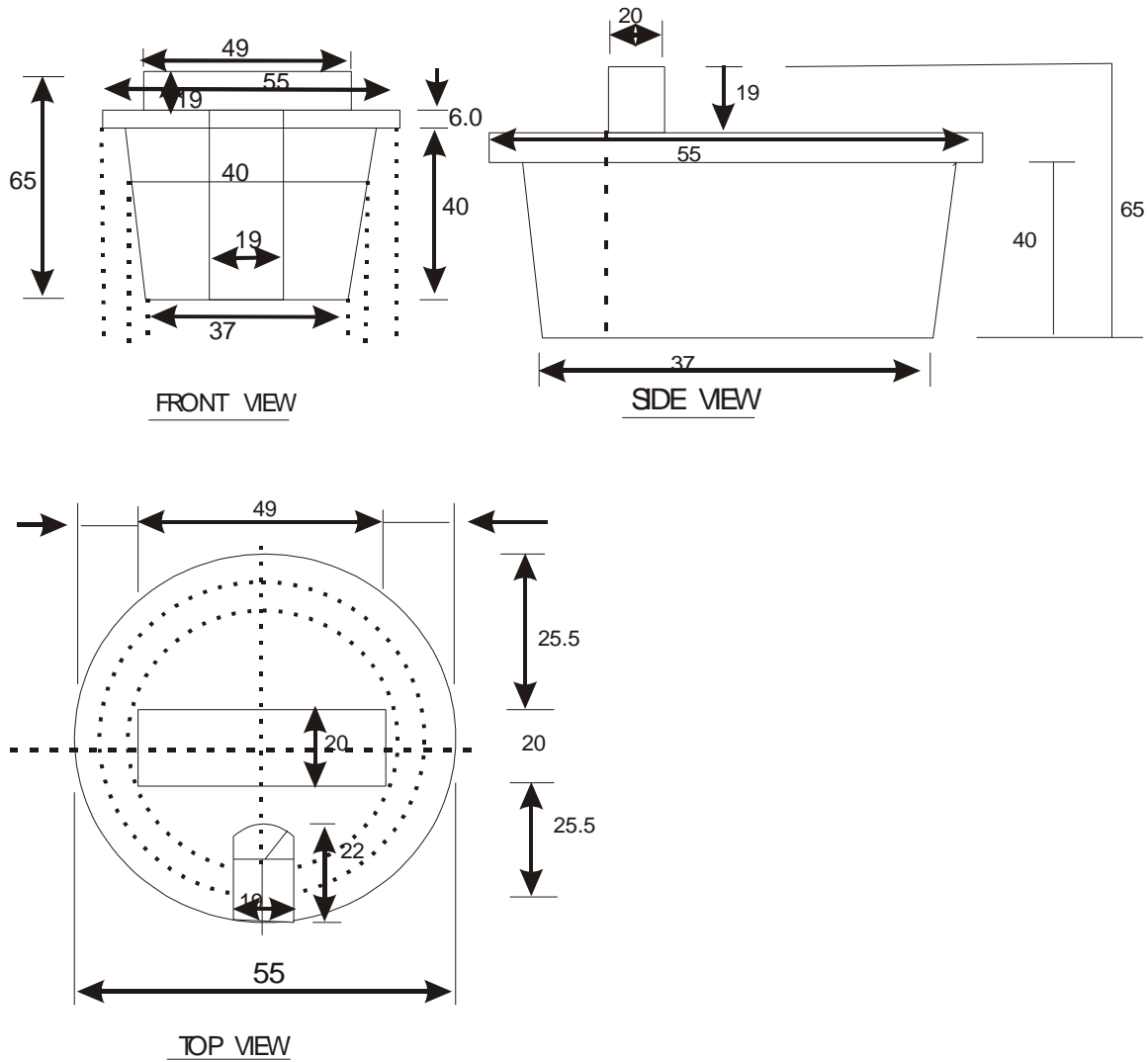

NOTE:

1. ALL DIMENSIONS ARE IN MM.
2. DIMENSIONS ARE ONLY FOR GUIDENCE. TAPPER SHOULD BE SUCH THAT IT SHOULD TIGHTLY FIX. INTO TYPE A & TYPE B HOPE 50 mm OO PIPES.

Fig. 4

M.S. WELDMESH

The HDPE/PLB pipes are protected by embedding it in concrete of s/c of 25 cms. 25 cms reinforced with MS weld mesh. The MS weld mesh should be of 50 mm x 100 mm size, 12 SWG of size, 120 cms in width in rolls of 50 m each. One meter of MS weld mesh caters to 3 meters of concreting. (See figure '3' for details).

DETAILS OF 100 MM X 50 MM, 12 SWG MILD STEEL WELD MESH HAVING WIDTH OF 120 CM.

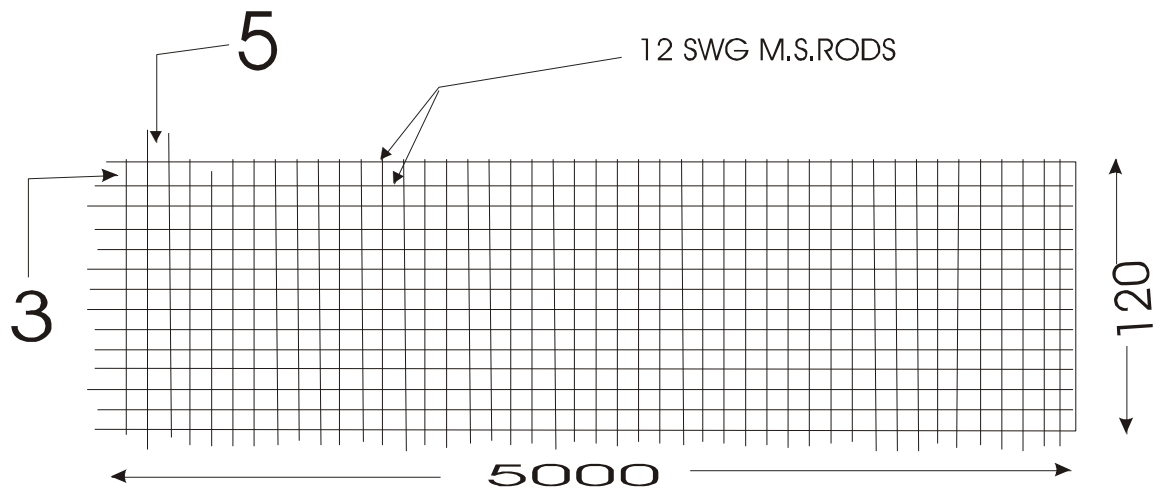

Note : All measurements are in centimeters.

Fig. 5

SPECIFICATION AND REINFORCEMENT DETAILS OF R.C.C. JOINT PROTECTION CHAMBERS

R.C.C. COLLAR

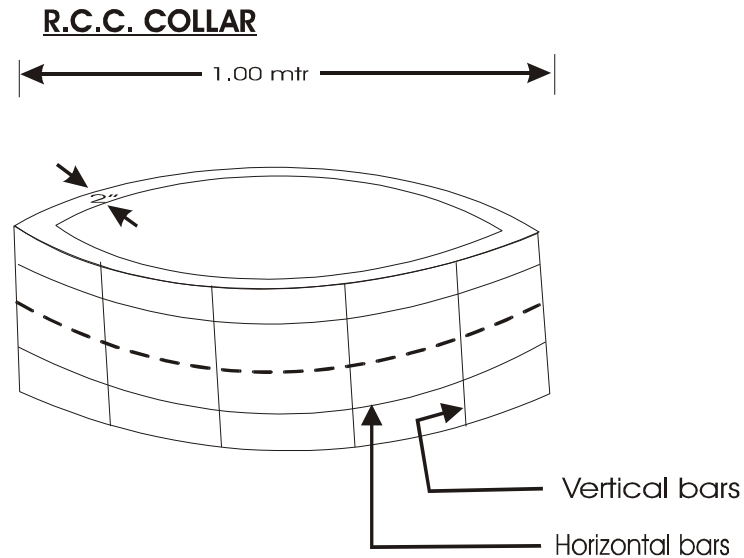

Specification:

1. Diameter : 1.00 Meter (inner side)
2. Thickness: 5 cm.
3. Height: 50 cm.
4. 6 mm Horizontal Iron round rings – 4 Nos.
5. 6 mm vertical bars Iron – 12 mm Nos.
6. 12 gauge GI wire mesh to be wrapped before reinforcing the concrete.

Note:

- a) Concrete 'Mix. 1: 2:3 (1 Cement: 2 Sand: 3 graded Stone aggregate 20 mm nominal size.
- b) Finishing: Smooth

Other conditions:

1. Prepared reinforcement to be shown to the DET OFC (P) FUNE on his representative before pouring Cement.
2. Concrete mixing to be made in his presence
3. The words O F C to be inscribed on top and bottom covers.
4. The top and bottom covers should also be reinforced and two handles should be provided for top cover & bottom covers.

Fig. 6

Route Indicator:

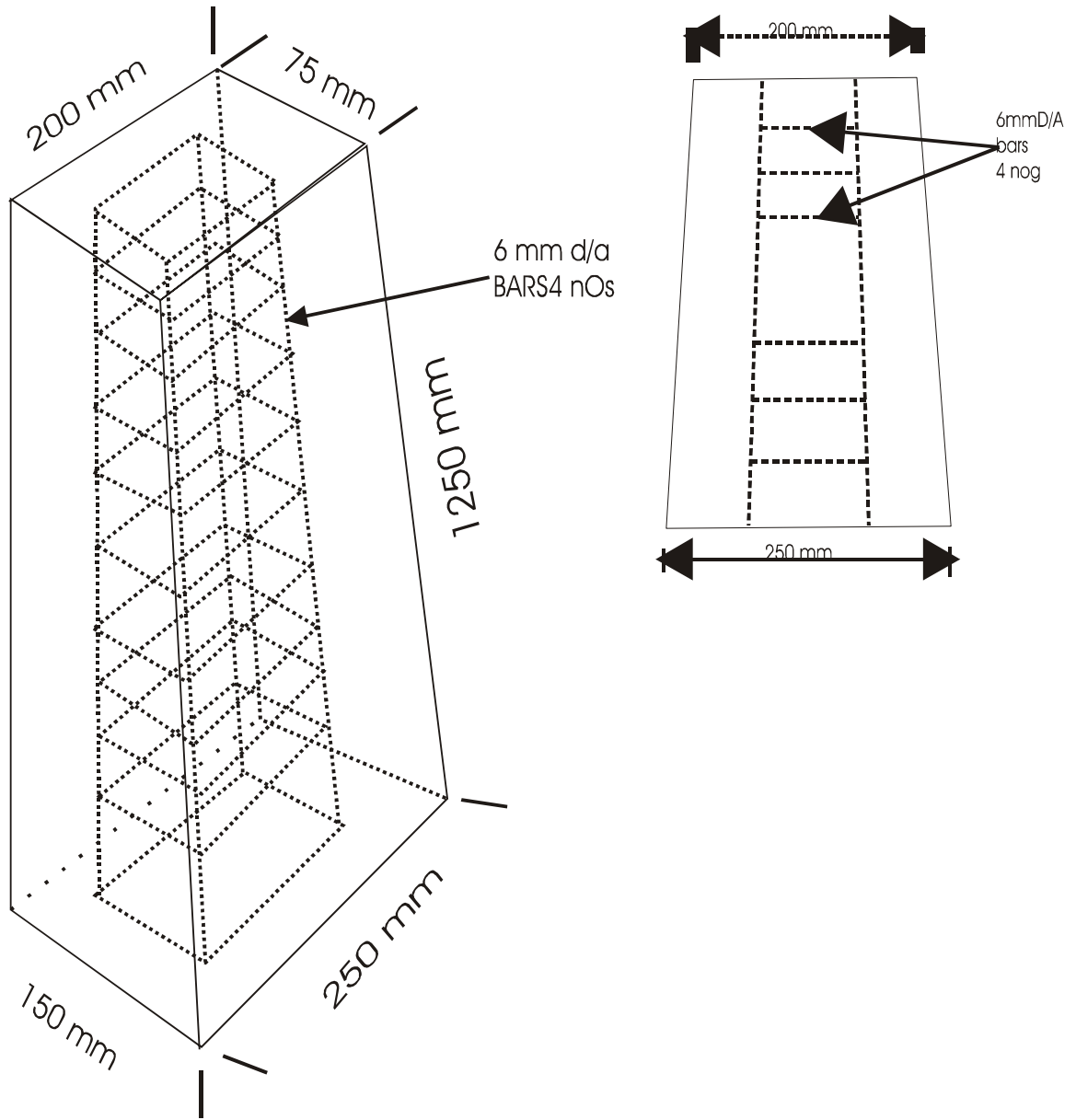

CHAPTER VII QUESTIONNAIRE

A) TENDERER'S PROFILE

Passport size
photograph of the
tenderer/authorized
signatory holding
power of Attorney

1. Name of the tenderer/firm:

Name of person submitting the tender, whose Photograph is
Shri/ Smt

(In case of Proprietary/ Partnership firms, the tender offer should be signed by the Proprietor/ Partner/ by any person authorized by him for this purpose having original power of attorney, as the case may be.)

2. Complete Postal Address of the firm :

3. Telephone No.(with STD code) :

- a) Office No. :
- b) Fax No :
- c) Mobile No :
- d) Residence No.:

4. Registration Particulars of the firm:

- i) Proprietorship
- ii) Partnership
- iii) Private Limited
- iv) Public Limited

(Please attach attested copies of documents of registration of your firm with the competent authority as required by business law)

5. Name of Proprietor/ Partners/ Directors

S. No.	Name of Person	Working as
1		
2		
3		
4		

Signature of contractor
With name and rubber stamp

6. Tenderer's bank, its address and his current account number

7. Permanent Income Tax account number, Income Tax circle

.....

8. Particulars of vehicles available with the tenderer which would be engaged in in OFC construction work :

S.N.	Type of Vehicle(s)	Registration number
1		
2		
3		
4		

9. Particulars of other machines possessed by the contractor which can help in Trenching, pipe laying and cable blowing :

S.N.	Name of machine	Quantity	Remark
1			
2			
3			

9.1 I can undertake OF Cable work @ no. of times of (1 Km/week)

10. **Details of Technical and supervisory Staff:**

S.N.	Name	Qualification	Since when working
1			
2			
3			
4			

Signature of contractor
With name and rubber stamp

11. Is the item of work specified in the tender form, sufficient to complete the work : Yes/No

11.1 If no, give details :

S.No.	Item of work	Unit of measurement	Rate/unit
1			
2			

12. Do you find that the scheduled rate of any item is unduly low/high : Yes/ No

12.1 If yes, give details :

S.No.	Item of work	Unit of measurement	Scheduled rate	Rate suggested
1				
2				
3				
4				

13. Do you find any deficiency in tender document : Yes/No

13.1 If yes, give details :

Signature of contractor
name with rubber stamp

14. CERTIFICATE

I.....S/o.....Reside
nt of..... hereby certify
that :-

- (a) none of my employee are near relative(s) of the Officers working in the office of GMTD, Shimla.
- (b) none of my employee/partner/director including me is employee of BSNL/MTNL.
- (c) I will not employ any employee in future who fails to meet clause 'a' & 'b' above till the validity of this contract.

In case, at any stage, it is found that the information given by me is false/incorrect, GMTD Shimla shall have the absolute right to reject my offer/cancel the awarded work and/or to take any action as deemed fit by him.

I/We hereby declare that the information furnished above is true and correct.

Place:

Date:

Signature of tenderer/Authorized signatory.....
Name of the tenderer.....
Seal of the tenderer

Note : Giving information in clause 11 to 13 shall not make the tender non- responsive.

Signature of contractor
With name and rubber stamp

BID FORM

Tender No. _____ Date: _____

To

The AGM (Planning),
Telecom. District,
Shimla

_____.

Dear Sir,

Having examined the conditions of contract and specifications including addenda No. the receipt of which is hereby duly acknowledged, we, undersigned, offer to execute the work of Optical Fiber Cable Construction Work in conformity with said drawings, conditions of contract and specifications as may be ascertained in accordance with the schedule of prices attached herewith and made part of this Bid.

We undertake, if our Bid is accepted, we will execute the work in accordance with specifications, time limits & terms and conditions stipulated in the tender document.

If our Bid is accepted, we shall submit the securities as per the conditions mentioned in the contract.

We agree to abide by this Bid for a period of 150 days from the date fixed for Bid opening (Qualifying Bid) and it shall remain binding upon us and may be accepted at any time before the expiry of the period.

Until a format Agreement is prepared and executed, this Bid together with your written acceptance thereof in your notification of award shall constitute a binding contract between us.

Bid Submitted by us is properly sealed and prepared so as to prevent any subsequent alteration and replacement.

Dated this..... Day of(The year)

Signature of Authorised Signatory

In capacity of

Duly authorised to sign the bid for and on behalf of

Witness.....

Address.....

Name of work- Laying of OFC in Patches under jurisdiction of Shimla & Rohru Telegraph Divisions

Quantum of Work with rates as per approved SOR

SN	Description of work	Total Quantum	Unit of Measurement	Rates Per unit (In Rupees)
1.1	Excavating trenches of dimensions (Width 0.45 m top and 0.30 bottom) up to a depth of 165 cm, dressing sides, bed leveling and dewatering of rain water and back filling the excavated trenches after laying the HDPE pipe with or without protection including diversion for traffic, night signals, fixing of caution boards, watching, fencing, cutting trees and bushes etc. and sundries lump sum .		-	-
	A. Non-Rocky soil (SOFT SOIL)	10400	Per Mtr	84.85
	B. Rocky-soft soil(Soft soil mixed with boulders,concrete and/ or bitumen) (SOFT ROCK)	6000	Per Mtr	212.97
	C. Rocy-hard soil (HARD ROCK)	5200	Per Mtr	412.36
2	Laying of HDPE pipes/coils with leveling alongwith fixing with HDPE sockets /HDPE couplers and laying of 40/33mm PLB in GI pipe /DWC pipe including carriage from stores	21600	Per Mtr	7.00
3	Laying of PLB Pipe/GI pipe duct through horizontal manual boring method for Road/Rail crossing including transportation of GI pipe for laying of 40 mm PLB pipe. (The GI Pipe of 65mm dia will be supplied by BSNL)	0	Per Mtr	130.00
4.1	Laying with levelling and fixing of GI pipe/DWC of 65 mm outer diameter through clamps on the wheel guard of the bridge and laying 40mm PLB inside GI /DWC pipes including transportation for laying of 40 mm PLB pipe. (The GI Pipe/DWC pipes of 65mm dia & 40mm PLB will be supplied by BSNL) . All other material and equipment /tools required for executing the said work are to be supplied by the contractor.	0	Per Mtr	20.25
4.2	Laying with levelling and fixing of Full DWC round pipe out side and below parapet wall of the bridge duly fixed by clamps at 1 meter interval and transportation for laying of 40 mm PLB pipe for the bridges more than 100 Meters. BSNL will supply DWC pipes. All other material and equipment/tools required for executing the said work shall be supplied by the contractor.	0	Per meter	80.00
4.3	Supply of Clamps per KG (with gauze 5mm) As per instructions of field DET	0	Per Kg	75.00
5.1	Laying with levelling and fixing of GI Pipes of 65 mm outer diameter in the trench including transportation for laying of 40 mm PLB pipe. (The GI Pipe of 65mm dia & 40mm PLB will be supplied by BSNL)	0	Per Mtr	18.40

5.2	Laying with levelling and fixing of Full Round DWC/ Full round RCC pipe including transportation for laying of 40 mm PLB pipe. (The Full round DWC Pipe/RCC/PLB Pipe 40mm PLB will be supplied by BSNL)	0	Per Mtr	12.00
5.3	Laying with levelling and fixing of half Round (Split) DWC pipe/ Split RCC Pipe including transportation. (The half round (split) DWC Pipe/RCC of 90mm dia will be supplied by BSNL)	2700	Per Mtr	7.50
5.4	Providing CC of size 25 Cms X 25 Cms for enclosing G.I./ PLB pipe of diameter upto 65 mm with CC of ratio 1:2:4 including transportation supply of all material for CC work by the contractor in presence of site incharge.(The GI Pipe of 65mm dia & 40mm PLB will be supplied by BSNL)	8900	Per Mtr	Rs.200/m or Rs. 3200 per Cubic M
5.5	Laying of 65 mm GI Pipe and Providing RCC of size 25 Cms X 25 Cms for enclosing GI pipes of diameter 65 mm with CC of ratio 1:2:4 with 4 nos of 6 mm dia iron rods with rings at interval of 0.5 M of 6 mm dia iron rods for fixing including supply of all material in presence of site incharge (The GI Pipe of 65mm dia & 40mm PLB will be supplied by BSNL)	1250	Per Mtr	Rs.250/m or Rs.4000 per Cubic M
6.1	Opening of Brick Chamber, Blowing 24F O.F.Cable, Sealing of HDPE/PLB Pipes by Rubber Bushes in Brick Chamber, providing HDPE/RCC/DWC Split Pipes in the chambers & Back Filling it. BSNL will supply OF cable, rubber bush, split RCC/HDPE pipes. All other materials and equipment required for executing the said work shall be arranged by the contractor.	23700	Per Mtr	12.00
6.2	Opening of Manhole of Existing Civil duct/ OAN ducts ,De-watering of Manholes, Repairing & clearing of Existing Civil duct, Pulling O.F.Cable, Sealing of HDPE/PLB Pipes by Rubber Bushes in Manholes, providing HDPE in the chambers & closing of Manholes etc. BSNL will supply OF cable, rubber bush, split RCC/HDPE pipes. All other materials and equipment required for executing the said work shall be arranged by the contractor.	0	Per Mtr	20.00
7.1	Digging of pit for jointing chamber and a)Supply & Fixing of Pre -cast RCC chamber with CC ratio 1:2:4, complete with base plate, filling of RCC chamber with clean sand, placing of Pre-cast RCC slabs on RCC chamber (as per Figure 7 Section VIII of tender document) and back filling the pit with fine sand including transportation of Pre-cast RCC chamber.from divisional store to work site.	0	Per chamber	Rs.5000 for supply & fixing, 1200 for fixing only

7.2	b) Digging of pit and Making of Bricks Joint Chamber having internal dimensions of 1.2 m x 1.2 m x1 m (H) having wall thickness of 9" using cement mortar mix of 1:5 (1: cement, 5: fine sand).to be constructed on the base of size 1.7 m x 1.7 m x 0.15 m (thickness).with cover & back filling the pit with fine sand as per construction specification of Clause 7.1 of Section VIII including cost of material & transportation..	70	Per chamber	5800.00
8	Splicing of all the fibers of OF cable laid at every joint and making termination at the ends.		-	
	a) 24/48 fibers	70	Per Joint/ Termination	3300.00
	b) 96 fibers	0	Per Joint/ Termination	6400.00
	c) 288 fibers	0	Per Joint/ Termination	8400.00
9	A. Digging of pit 1 meter towards jungle side on each manhole/joint/route chamber for fixing of route/joint indicator, transportation from stores to locations, a)Supply & Fixing of Route Indicators including transportation concreting,painting and sign writing with paint(as per specifications Fig.6 under Section VIII of the Tender Document) B) Fixing with concreting of Route Indicators, painting & Signwriting with paint(as per specifications Fig.6 under Section VIII of the Tender Document)to be done by Contractor,including transportation . BSNL will supply the route indicators.	0	Per Indicator	a)Rs.620 for supply & fixing b)Rs.420 for supply only c)Rs. 180 for fixing only
10	Supply of route index diagram in 3 Nos of hard colour copies as well as Two soft copy on CD.	0	Per set of three copies	250.00 per km
11	Digging of pit for Manhole chamber and making of RCC Manhole chamber complete With cover & backfilling the pit as per specifications mentioned in the tender document. (As per specification in BSNL)	0	Per manhole	42000.00
12	Supply & fixing of FRP Manhole as per specifications mentioned in the tender document. The Contractor shall arrange all materials and equipment required for work (As per specification in BSNL)	0	Per Manhole	30000.00
13	Cost of recovery empty cable drums of size 24/48/96/288 fibers	13	Per drum	400.00

Other Terms and Conditions:-

1. It will be the responsibility of the contractor to obtain ROW/ Permission for this purpose .The contractor shall have to liaison with various authorities on behalf of BSNL.
2. Payment of ROW/ Permission charges for reinstatement to Govt. agencies will be made over by BSNL.
3. All the stores to be supplied by BSNL are to transported by contractor from BSNL store of concerned DE OFC incharge of the work.
4. The contractor will have to lay either DWC split or RCC split or stone slabs as protection as per directions of the SDE/DE in charge of the route on the approval of SSA Head
5. Item at S.No. 9 i.e. supply of route indicators is optional. The contractor will have to provide it as per directions of DE Concerned , If not provided by BSNL.
6. Applicable DOT/ BSNL instructions regarding the subject matter are to be strictly followed.
7. In rocky area tender may be called for maximum depth 140cm and in schedule the rate for 165,140,120,100,70,50 cm should be mentioned.
8. In rocky area all efforts should be done to get minimum 60 cm depth.
9. The experience of contractors worked with private telecom operators/ infra service providers may also be included in NIT.

Copy of Price Bid – For View Purpose Only

(Bidder has to submit (upload) financial bid online in excel file on www.tenderwizard.com/BSNL. The price bid shall not be submitted in hard copy in any case alongwith eligibility documents)

Financial Bid

To

The General Manager
Telecom District, Shimla

Subject : The Rates for Laying of U/G OFC in Patches in Shimla & Rohru Telegraph
Telegraph Divisions

NIT No: **002/515/2016-17/Tender/OFC Patch Work/PIg/ Vol-II/06 Dated: 27.08.2016**

Dear Sir,

Having examined the tender documents, terms and condition stipulated therein specifications of work etc. signed offer to execute the Optical cable construction works in conformity with the said specifications and condition of contract at the percentage (Below/at par /above) on standard schedule rates quoted as under :

Name of Bidder>>	
Please mention in box "below" or "at par" or "above" >>	
Please mention % in figures >>	
Please mention % in words >>	